

**Thanks for buying the  Wouxun KG-UV920R transceiver.**

**This transceiver Offers latest design, enhanced features, solid performances and easy accessibility. We believe you will be pleased with the high quality and reliable features for all your communication needs.**

Read this important information on the safe and efficient operation before using mobile transceiver. This manual is suitable for KG-UV920R

 **Wouxun**

Twin Band FM Transceiver

## **User Safety, Training, and General Information**

READ THIS IMPORTANT INFORMATION ON SAFE AND EFFICIENT OPERATION BEFORE USING YOUR  **Wouxun** PORTABLE TWO-WAY RADIO.

### **Compliance with RF Energy Exposure Standards**

Your  **Wouxun** two-way radio is designed and tested to comply with a number of national and international standards and guidelines (listed below) regarding human exposure to radio frequency electromagnetic energy. This radio complies with the IEEE (FCC) and ICNIRP exposure limits for occupational/controlled RF exposure environment at duty cycles of up to 50% talk-50% listen and should be used for occupational use only. In terms of measuring RF energy for compliance with the FCC exposure guidelines, your radio radiates measurable RF energy only while it is transmitting (during talking), not when it is receiving (listening) or in standby mode.

#### **NOTE**

» The approved batteries supplied with this radio are rated for a 5-5-90 duty cycle (5% talk-5% listen-90% standby), even though this radio complies with the FCC occupational RF exposure limits at duty cycles of up to 50% talk.

## Your two-way radio Complies with the following of RF energy exposure standards and guidelines:

- United States Federal Communications Commission, Code of Federal Regulations; 47CFR part 2 sub-part J
- American National Standards Institute (ANSI)/Institute of Electrical and Electronic Engineers (IEEE) C95. 1-1992
- Institute of Electrical and Electronic Engineers (IEEE) C95. 1-1999 Edition
- International Commission on Non-Ionizing Radiation Protection (ICNIRP) 1998

### Operational Instructions and Training Guidelines

To ensure optimal performance and compliance with the occupational/controlled environment RF energy exposure limits in the above standards and guidelines, users should transmit no more than 50% of the time and always adhere to the following procedures:



#### Transmit and Receive

To transmit (talk), push the Push-To-Talk (PTT) button; to receive, release the PTT button.



#### Hand-held radio operation

Hold the radio in a vertical position with the microphone 5 cm away from the lips and keep the antenna far away from your head.

#### Body-worn operation



Always place the radio in an  approved clip, holder, holster, case, or body harness for this product. Use of non- -approved accessories may exceed FCC RF exposure guidelines.

#### Antennas & Batteries

- Use only  approved, supplied antenna or  approved replacement antenna.
- Unauthorized antennas, modifications, or attachments could damage the radio and may violate FCC regulations.



Twin Band FM Transceiver

- Use only  approved, supplied batteries or  approved replacement batteries.
- Use of non- -approved batteries may exceed FCC RF exposure guidelines.



#### Approved Accessories

For a list of  approved accessories, see the accessories page of this user manual or visit the following website which lists approved accessories: <http://www.wouxun.com>

#### Notices to the User

- Government law prohibits the operation of unlicensed radio transmitters within the territories under government control.
- Illegal operation is punishable by fine or imprisonment or both.
- Refer service to qualified technicians only.

#### **Warning**

- » It is important that the operator is aware of and understands hazards common to the operation of any transceiver. For example, Explosive environments (such as gases, dust, fumes, etc). Turn off your transceiver while refueling, or parking in gasoline service stations.
- » If you require this machine to be developed or get some changes, please contact with  or your  dealer.

#### FCC Caution:

This equipment has been tested and found to comply with the part 90 of the FCC Rules. These limits are designed to provide reasonable protection against harmful interference in a residential installation. This equipment generates, uses and can radiate radio frequency energy and, if the equipment is not installed and used in accordance with the instructions, it may cause harmful interference to radio communications. However, there is no guarantee that interference will not occur in a particular installation.

If this equipment does cause harmful interference to radio or television reception, which can be determined by turning the equipment off and on, the user is encouraged to try to correct the interference by one or more of the following.

**Measures:**

- Reorient or relocate the receiving antenna.
- Increase the separation between the equipment and receiver.
- Connect the equipment into an outlet on a circuit different from that to which the receiver is connected.
- Consult the dealer or an experienced radio/TV technician for help.

**FCC Licensing Requirements**

Your radio must be properly licensed Federal Communications Commission prior to use. Your **Wouxun** Wireless dealer can assist you in meeting these requirements. Your dealer will program each radio with your authorized frequencies, signaling codes, etc., and will be there to meet your communications needs as your system expands.



Twin Band FM Transceiver

**Precautions**

Only qualified technicians are allowed to maintain this product.

Do not use the radio or charge a battery in explosive areas such as coal gas, dust, steam, etc.

**Switch OFF the radio while refueling or parking at a gas station.**

Do not modify or adjust this radio without permission.

Do not expose the radio to direct sunlight over a long time, nor place it close to heat source.

Do not place the radio in excessively dusty, humid areas, nor place close to heating appliances.

Safety: It is important that the operator is aware of and understands hazards common to the operation of any radio.

**This device complies with Part 15 of the FCC Rules.**

Operation is subject to the following two conditions:

- (1) this device may not cause harmful interference, and
- (2) this device must accept any interference received, including interference that may cause undesired operation.

**Warning**

» MODIFICATION OF THIS DEVICE TO RECEIVE CELLULAR RADIOTELEPHONE SERVICE SIGNALS IS PROHIBITED UNDER FCC RULES AND FEDERAL LAW.

## CE Caution:

Hereby,  **Wouxun** declares that this Two-way radio is in compliance with the essential requirements and other relevant provisions of Directive 1999/5/EC.

A copy of the DOC may be obtained through the following address.

Address: No.928 Nanhuan Road, Jiangnan High Technology Industry Park, Quanzhou, Fujian 362000, China

## Please note



Twin Band FM Transceiver

 **Wouxun** The transceiver features good design and advanced technology. The following advice will help you to maintain the product, and understand and know how to use it safely.

1. Please do not attempt to open the product. Handling of this product by non-professionals may cause damage.
2. Please use the antenna provided by this company, to avoid reducing the usage range.
3. Please do not expose the transceiver to direct sunlight for an extended period of time, or place it in an excessively hot area.
4. Please do not place the radio in excessively dusty or humid areas.
5. Please do not use strong chemicals, detergents, or strong cleaning agents to wash the transceiver.
6. Please do not transmit from the transceiver before the antenna has been installed.
7. If you discover any irregularities or smoke coming from the transceiver, please disconnect the transceiver's power source immediately, disconnect the power cable, and contact the  **Wouxun** dealer.

## Notice

» All of the above advice is suited to the use of your  **Wouxun** transceiver and its accessories. If they do not function normally, please get in touch with the  **Wouxun** dealer immediately.

» If you use components or accessories not sold by Wouxun Company, Wouxun will not guarantee the safety and usability of the transceiver.

## Contents

<b>Checking the equipment</b> .....	1
<b>Description of functions</b> .....	2
<b>Technical specifications</b> .....	3
<b>Pre-Use Installation</b> .....	4-6
Transceiver .....	4
Connecting power source .....	6
Antenna connection .....	7
Front panel installation .....	8-11
Accessories installation .....	11-12
<b>Getting started</b> .....	13-16
Front panel .....	13
LCD .....	14
Back panel .....	15
Side panels .....	15
Handheld microphone .....	16
<b>Your first QSO</b> .....	17-21
Commonly used basic operations .....	21
Adjust Volume .....	21
Select dual display/ single display mode .....	21
Select VFO/ MR mode .....	21
<b>Shortcut operation chart</b> .....	22
<b>Menu operation sheet</b> .....	23-26
<b>Function description</b> .....	27-29

<b>How to use Shortcut function</b> .....	28-32
<b>Menu Operation</b> .....	33-50
Step frequency settings (STEP) -----Menu 1 .....	33
Wide/Narrow bandwidth settings (W/N) -----Menu 2 .....	33
Medium power settings ( MPOW-SET ) ----- Menu3 .....	33
Offset frequency settings (OFF-SET) -----Menu4 .....	34
Transmission prompt display settings ( ROGER ) ----- Menu5 .....	34
Beep prompt settings (BEEP) ----- Menu 6 .....	34
Voice prompt settings (VOICE) -----Menu 7 .....	34
Busy channel lock-out (BCL) -----Menu 8 .....	35
Squelch settings ( SP-MUTE ) ----- Menu9 .....	35
Scan mode settings ( SC-REV ) ----- Menu10 .....	36
Time-out timer ( TOT ) ----- Menu11 .....	36
Transmission overtime alarm ( TOA ) ----- Menu12 .....	36
Caller ID switch ( ANI-SW ) ----- Menu13 .....	37
Ring time (RING) ----- Menu 14 .....	37
Editing Caller ID (ANI-EDIT) ----- Menu 15 .....	37
Dual-tone sidetone settings (DTMFST) ----- Menu 16 .....	38
Caller ID transmission mode (PTT-ID) ----- Menu 17 .....	38
Transmission backlight (TX-LED) ----- Menu 18 .....	38
Waiting backlight (WT-LED) ----- Menu 19 .....	39

## Contents

Receiving backlight (RX-LED) ----- Menu 20 .....	39
Deleting a channel (DEL-CH) -----Menu 21 .....	39
Editing channel name (CH-NAME) Menu22 .....	39
Priority channel switch (PRICH-SW)----- Menu23 .....	40
Speaker settings (SP- CONT)----- Menu24 .....	40
Keypad AutoLock (AutoLock)----- Menu25 .....	41
Receiver CTCSS ( RX-CTC ) ----- Menu26 .....	41
Receiver CDCSS ( RX-DCS ) ----- Menu27 .....	41
Transmitter CTCSS ( TX-CTC ) ----- Menu28 .....	41
Transmitter CDCSS ( TX-DCS ) ----- Menu29 .....	41
Repeater speaker switch ( RPT-SPK ) ----- Menu30 .....	42
Repeater PTT switch ( RPT-PTT ) ----- Menu31 .....	42
Repeater Settings ( RPT-SET ) ----- Menu32 .....	43
Scan Add ( SCANADD ) ----- Menu33 .....	44
Automatic power-off ( APOTIME ) ----- Menu34 .....	45
Single-tone Pulse frequency (ALERT)----- Menu35 .....	45
Companding----- Menu36 .....	46
Temperature testing ( AUTOFAN ) ----- Menu37 .....	46
Voltage Testing (LOW -V)----- Menu38 .....	46
Voice Scrambling (Scram)----- Menu39 .....	47
CTCSS scanner save type ( SC-QT ) ----- Menu40 .....	47

Reduced noise settings ( ANS ) ----- Menu41 .....	48
Scanner group settings ( SC-GROUP ) ----- Menu42 .....	48
FM radio function ( FM-RADIO ) ----- Menu43 .....	48
Reset settings (Reset)----- Menu44 .....	48
<b>Using FM Receiver mode</b> .....	49-50
Opening FM Receiver mode .....	49
Frequency selection of FM Receiver mode .....	49
storing FM Receiver mode .....	49
Exiting FM Receiver mode .....	50
<b>Repeater usage</b> .....	51
Duplex cross-band repeater channel selection .....	51
Repeater PTT option .....	51
Repeater SPK option .....	51
Entering Duplex cross-band repeat .....	51
<b>Handheld microphone encoding function</b> .....	52
<b>Long range remote control usage</b> .....	52-56
Remote control activation .....	53
Long range stun .....	54
Long range kill .....	54
Long range monitoring .....	54
Long range inspection .....	54

## Contents

Long range remote control switch settings .....	55
Long range repeat channel control settings .....	56
<b>Optional Accessories</b> .....	57
<b>Troubleshooting</b> .....	58
<b>Announcement</b> .....	59

## Checking the equipment



Twin Band FM Transceiver

Carefully unpack the transceiver. We recommend that you identify the items in the following table before discarding the packing material.

If any item is missing or has been damaged during shipment, please notify your **Wouxun** dealer.

### Standard Accessories



Mobile/Base  
Transceiver



Hand  
Microphone

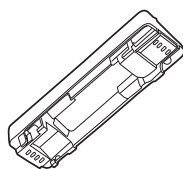

Inclined Switchboard  
Panel (Already Installed  
on Mobile Transceiver)

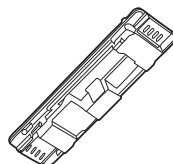

Flat Switchboard  
Panel

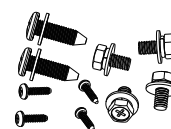

Screw Sets

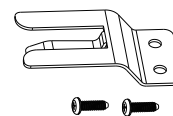

Hand  
Microphone  
Hook

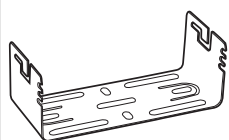

Mobile Mounting  
Bracket

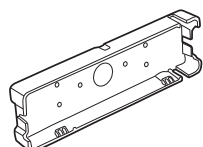

Remote Front  
Panel Bracket

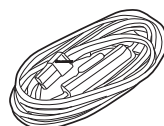

Mobile Power  
Cord

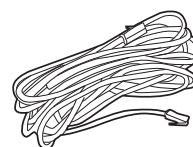

Extension  
Cable



User's manual

## Description of functions

### 1. Twin Band Transmit / Receive

(RX / TX) 136-174MHz & 400-470MHz  
 136-174MHz & 400-480MHz  
 136-174MHz & 216-280MHz  
 136-174MHz & 420-520MHz  
 144-146MHz & 430-440MHz  
 144-148MHz & 222-225MHz  
 144-148MHz & 420-450MHz  
 (RX) FM: 65MHz~108MHz ( 100K Frequency Spacing )

### 2. Band can be Set Freely

VHF TX-UHF RX or UHF TX-VHF RX

### 3. Dual Reception

Twin Band Simultaneous Reception

### 4. Dual Display

Large LCD Dual Frequency Display,  
 Two Completely Independent Operating Systems

### 5. Over 999 Memory Channels

Area Scanning Management

### 6. Remote-head Mounting Capacity

Multiple Installation Types, Convenient Usage

### 7. Cross-Band Repeat

UHF / VHF Cross-band Repeat or VHF / UHF  
 Cross-band Repeat Functions

### 8. Both Stations can Form Combined Same Band or Different Band Repeat

### 9. Strong and Stable Output Power ( VHF:50W / UHF:40W )

### 10. QT / DQT Encoding & Decoding, QT / DQT Scanning

### 11. Multiple Speaker Channel Settings

### 12. Individual Hand Microphone with TX / RX Indicator

### 13. Incoming Message Display

Caller ID display

### 14. DTMF Encoding and Decoding

### 15. Group Calls, All Calls and Selective Calls

### 16. 8 Groups Scrambler ( Optional )

### 17. Priority Channel Scanning

### 18. APO Power Management

### 19. English Voice Guide

### 20. Automatic Temperature Testing

### 21. Minimum Operating Voltage Settings

### 22. Stun and Kill Function

### 23. Single Tone Pluse Frequency

2100Hz / 1750Hz / 1450Hz / 1000Hz

( Used when activating repeater signal )

### 24. Three Colors Backlight Selectable

02

## Technical specifications



Twin Band FM Transceiver

General		Receiver	Wide bandwidth	Narrow bandwidth
Frequency Range	Frequency Range Suitable for any Region of any Country	Adjacent channel selectivity	≥ 70dB	≥ 60dB
		Intermodulation	≥ 65dB	≥ 60dB
		Spurious response	≥ 70dB	≥ 70dB
Step frequency	5KHz / 6.25KHz / 10KHz / 12.5KHz / 20KHz / 25KHz / 30KHz / 50KHz / 100KHz	Audio response	+1~-3dB(0.3~3KHz)	+1~-3dB(0.3~2.55KHz)
Memory Channels	999	Signal to noise ratio	≥ 45dB	≥ 40dB
		Step frequency	≤ 5%	
Work mode	F2D / F3E	Audio distortion	Transceiver ≤ 3W Hand Microphone ≤ 1W	
Operating Temperature	-20℃~+60℃			
Antenna Impedance	50Ω	Sensitivity	UHF/VHF:0.25μV	
Power Requirement	13.8VDC ± 15% (Negative Grounded)			
Weight	1437.8g (including microphone)			
Dimensions	140 x 44 x 207 (mm)			

Transmitter	Wide bandwidth	Narrow bandwidth	Transmitter	Wide bandwidth	Narrow bandwidth
Output Power	50W/20W/10W/5W(VHF)	40W/20W/10W/5W(UHF)	Spurious	≥ 60dB	≥ 60dB
Type of Modulation	16K F3E	11K F3E	Audio Response	+1~-3dB(0.3~3KHz)	+1~-3dB(0.3~2.55KHz)
Adjacent Channel Power	≥ 70dB	≥ 60dB	Max. Frequency Deviation	± 5KHz	± 2.5KHz
Signal to Noise Ratio	≥ 40dB	≥ 36dB	Frequency Stability	± 2.5ppm	
			Audio Distortion	≤ 5%	

03

## Pre-usage installation

### Transceiver installation

Choose a safe place inside your vehicle, one which would to the greatest extent reduce possible harm to passengers inside the car while the car is moving. It is recommended to install the transceiver on the lower part of the front meter gauge, it will prevent the transceiver from colliding with the driver in the instance of emergency or sudden braking. Install the transceiver in an area with good ventilation and avoid installing in a place with direct contact with the sun.

1. Use the supplied self-tapping screws to install the support bracket to the vehicle.

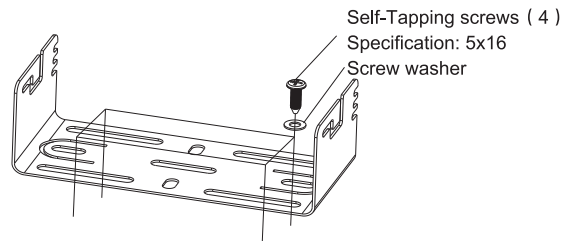

2. Set the transceiver in the bracket, then insert the supplied combined screws and tighten, insure that the screws are fastened tightly. This will insure the support bracket and the transceiver do not get bumped lose when the vehicle hits bumps or shakes.

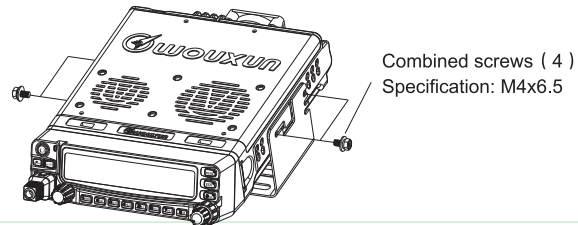

04

**WOUXUN**

Twin Band FM Transceiver

3. Use every screw slot along the side of the support bracket, you can set the transceiver to be installed at a different angle.

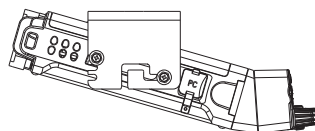
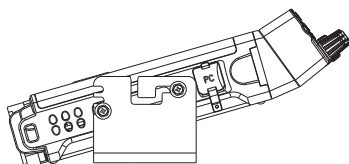
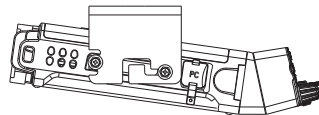
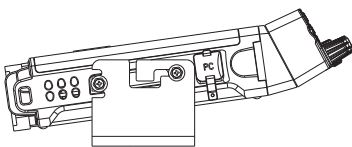
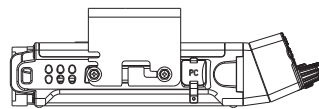
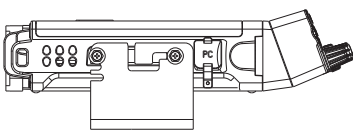

05

## Connect power

The transceiver power source usage ranges from  $13.8V \pm 15\%$ . When your power source (or vehicle power source) reaches levels up to 16V, TX will be forbidden, however RX will operate as normal. When your power source (or vehicle power source) reaches levels as low as 11.5V, the transceiver will automatically shut off. This is so the transceiver does not exhaust the vehicles battery and affect the vehicles normal operation. (This feature is set by the menu function, see instruction 46)

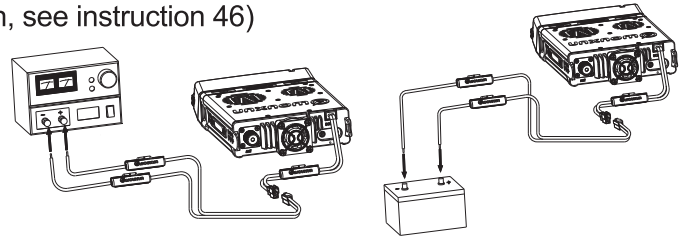

## Special Reminder

» This transceiver's working voltage is  $13.8V \pm 15\%$  DC

### ■ Replacing the fuse

In the instance that the transceiver blows a fuse, first find out the reason, then solve the malfunction. If after installing the new fuse it once again blows a fuse, please sever the power source and immediately contact a local authorized  dealer or service center for assistance.

The specified fuse current is 15A, The specified power source current is 20A and above.

See the Fuse installation diagram on the right, after installation the fuse should be firmly secured to the copper set!

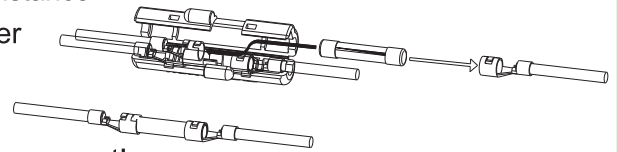

06

## Antenna connection



Twin Band FM Transceiver

Before operation, you must effectively install and adjust the antenna, installation success depends upon the type of antenna and whether or not the antenna is set up correctly. If you use the most suitable antenna and the antenna is installed correctly, the transceiver will attain the greatest results.

The transceiver antenna's impedance is 50 ohms, if the impedance is not at 50 ohms it will reduce the performance of the transceiver and possibly interfere with nearby broadcasting stations as well as other antenna's receivers, it could even harm the transceiver.

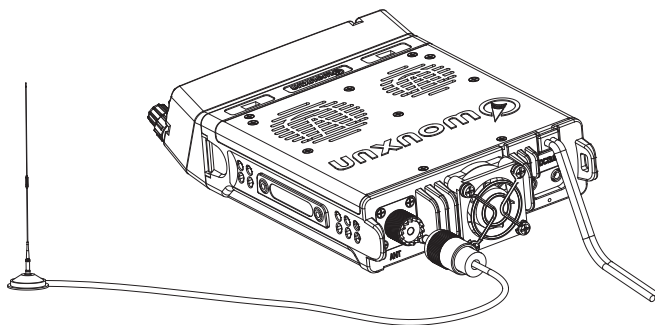

07

## Front panel installation

The transceiver is supplied with two kinds of switchboard panels: Inclined switchboard panel and a flat panel switchboard panel.

### ■ Install inclined switchboard panel

( 1 ) Lower alignment

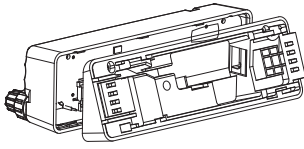

( 2 ) Cover alignment

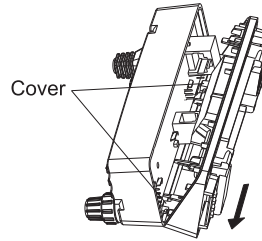

( 3 ) Close in the direction shown by the arrows

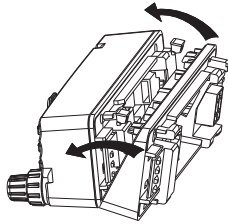

( 4 ) Use the supplied screws to fasten

Self-Tapping screws  
Specification: 2x16

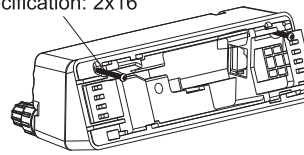

08

**Wouxun**

Twin Band FM Transceiver

### ■ Flat panel switchboard panel

( 1 ) lower Alignment

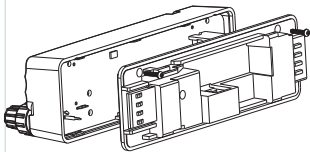

( 2 ) Cover Alignment

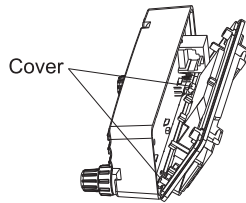

( 3 ) Close in the direction shown by arrows

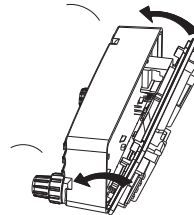

( 4 ) Use the supplied screws to fasten

Self-Tapping screws ( 2 )  
Specification: 2x11

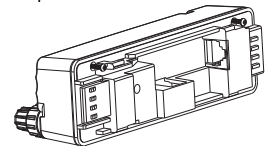

### ■ Front panel and main station installation

( 1 ) Connect the cable to the transceiver's 8 point socket

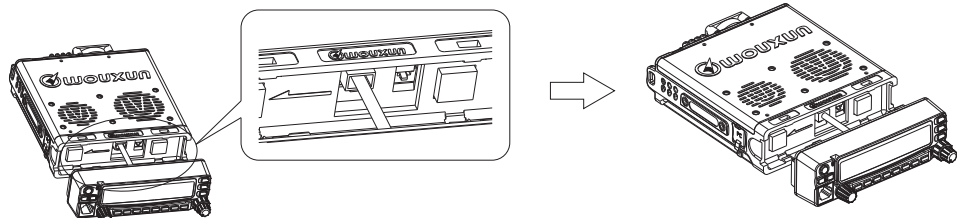

( 2 ) Proceed according to the arrow shown.

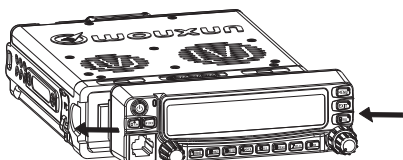

09

## Front panel installation

### Connection method for transceiver station to operating front panel line:

The vehicle transceiver connection line uses 8 facets and 8 lead conducting wires ( diagram 1 ) ,

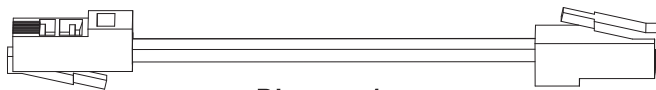
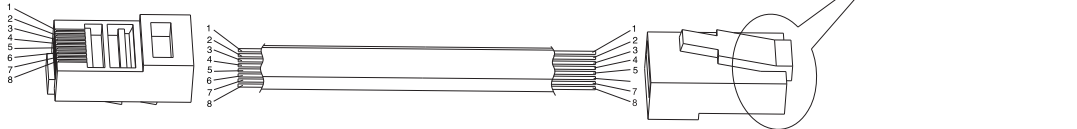

Diagram 1

The two ends of the facets connect to the corresponding line: ( Take note that direction of the connection lines on the left and right sides of the facet are not the same )



- Left facet connection point 1
- Left facet connection point 2
- Left facet connection point 3
- Left facet connection point 4
- Left facet connection point 5
- Left facet connection point 6
- Left facet connection point 7
- Left facet connection point 8

- Connect through the conducting wire to right facet 1
- Connect through the conducting wire to right facet 4
- Connect through the conducting wire to right facet 3
- Connect through the conducting wire to right facet 2
- Connect through the conducting wire to right facet 5
- Connect through the conducting wire to right facet 6
- Connect through the conducting wire to right facet 7
- Connect through the conducting wire to right facet 8

Therefore the conducting wires connection to the left facet is corresponding and the connection to the right facets 2 and 4 are swapped.

### Special Reminder

» If the connection wires are not **Wouxun** Company supplied or dealer approved, **Wouxun** Company does not guarantee its safety and operational effectiveness!

#### ■ Dismantling the front panel and transceiver

( 1 ) Disconnect cover in the direction of the arrow

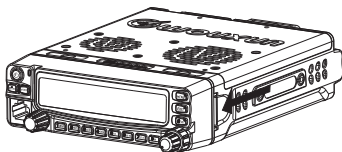

( 2 ) Remove in the direction shown by the arrow

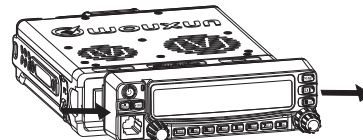

#### ■ Installation of front panel support bracket

When the transceivers front panel is installed separately from the main platform, there is a supplied front panel support bracket designed especially for installation.

( 1 ) First secure the support bracket with the supplied screws

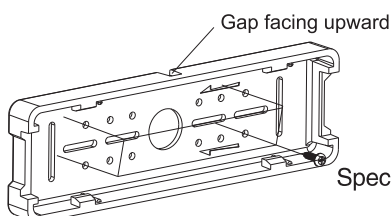

Specification: 2.3X8(4pcs)

## Installation of accessories

( 2 ) First string the connection line through opening in the center of the support bracket, then close the bracket cover directly as shown by the arrows.

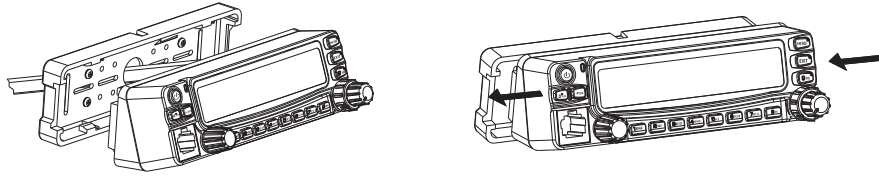

### ■ Outer speakers

The external speaker jacks can be connected to a 3.5mm single outlet. There are two speaker outlets located on the back of the transceiver.

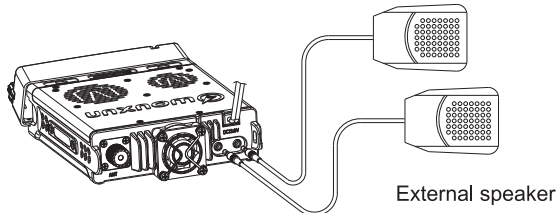

### ■ Handheld microphone installation

The transceiver comes supplied with two different types of handheld microphone : Encoded handheld microphone and unencoded handheld microphone. Plug the connection cable into the 8 point socket located on the front panel.

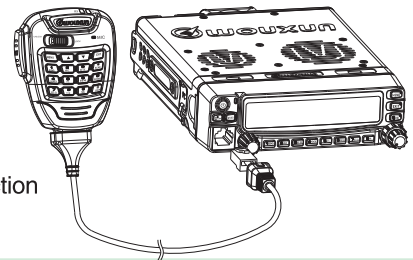

12

## Getting started

### Front panel

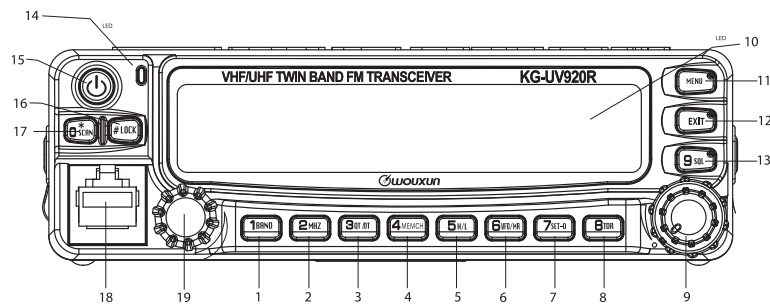

- 1 Master frequency set up hot key ( See hot key operation 1 )  
/ Single-tone pulse key ( see Menu36 )
- 2 Frequency or channel shortcut. ( See hot key operation 2 )
- 3 CTCSS encoding and decoding set up / CTCSS scanning  
( see hotkey operation 3 )
- 4 Save channel hot key ( see hot key operation4 )
- 5 Power output settings hot key
- 6 VFO/MR switch over hot key ( see hot key operation 6 )
- 7 Step frequency alternation hot key ( See hot key operation 7 )
- 8 TDR Single and dual display switch hot key  
( See hot key operation 8 )
- 9 Volume control ( See volume control )

- 10 LCD
- 11 Function keys/ enters keys
- 12 Exit/Cancel keys
- 13 Squelch level adjustment hot key ( See hot key operations 9 )
- 14 Status indicator light  
Orange waiting indicator light  
Green RX indicator light  
Red TX indicator light
- 15 Power switch button
- 16 Keyboard lock key ( See keyboard lock )
- 17 Scanning key ( See scanner function )
- 18 Handheld microphone outlet

**Wouxun**  
Twin Band FM Transceiver

## Getting started

### Display

All kinds of performance parameters can be selected on the LCD screen. Sometimes, you may be unable to think of what they mean or how to change them. The following table will be extremely useful at such times.

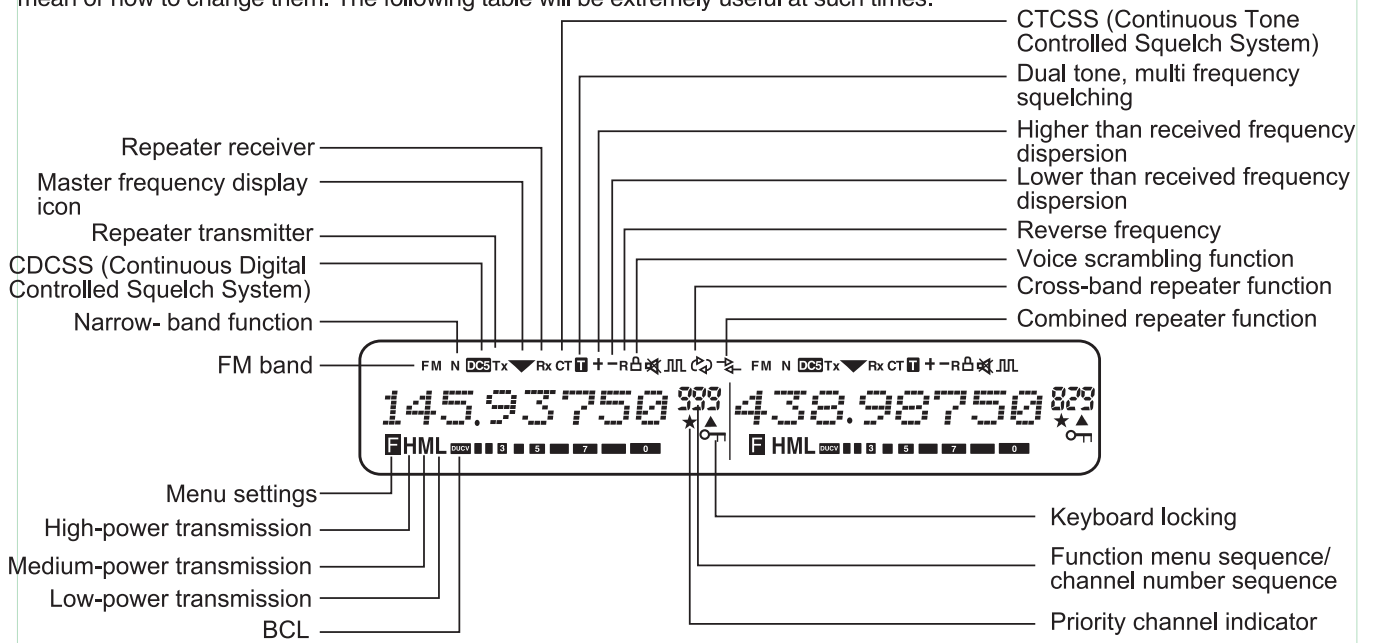

14

Wouxun

Twin Band FM Transceiver

### Back panel

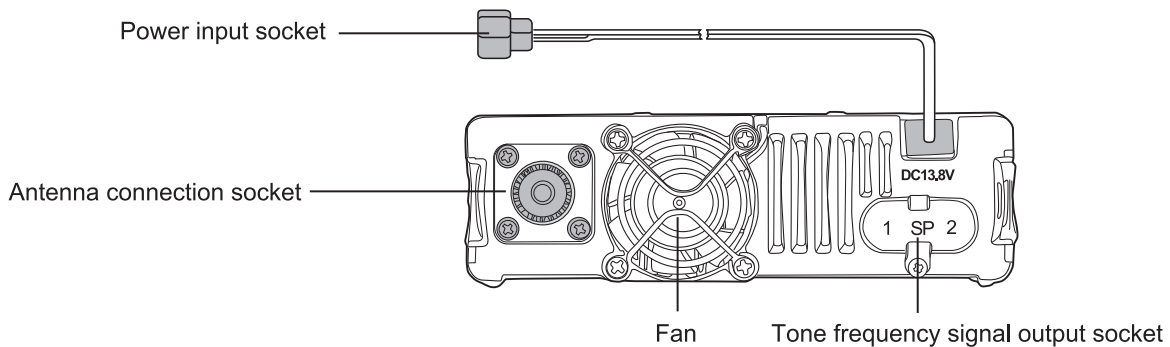

### Side panels

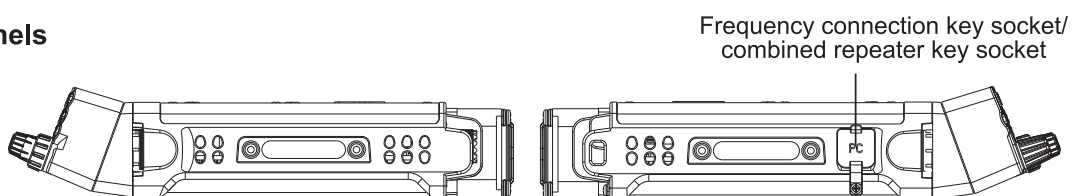

15

## Getting started

### Handheld microphone

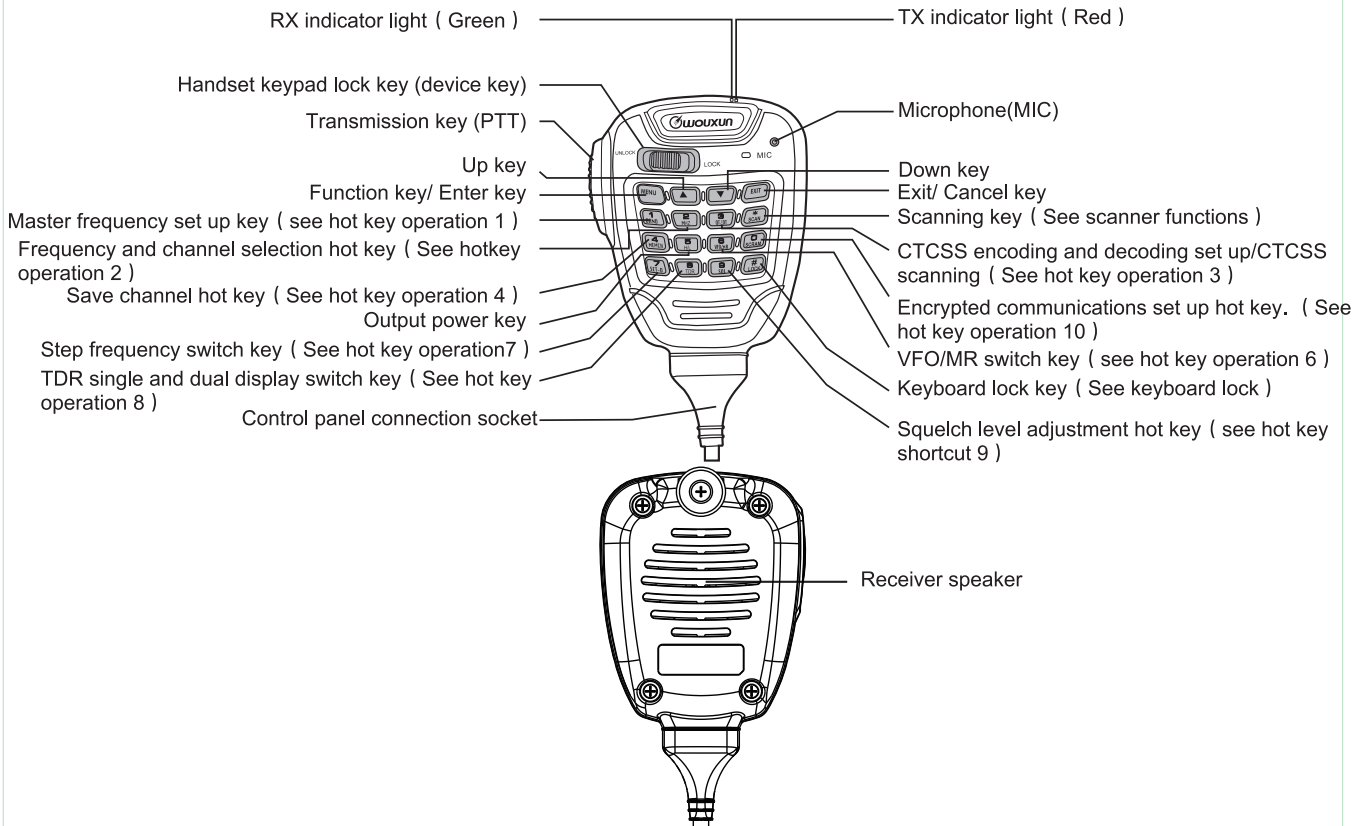

16

## Your first QSO

Wouxun

Twin Band FM Transceiver

### First QSO

Do you want to hurry up and use your transceiver? After reading these chapters and sections you will know how to broadcast your voice out into the sky. Following is a quick instruction Manual. If you encounter any problems or need further explanation, please read the detailed explanation later in this Manual.

1. Installing the transceiver ( See pre-usage installation )
2. Installing the antenna ( See pre-usage installation )
3. Installing the power source, or vehicle power source ( See pre-usage installation )
4. Press  to turn on the transceiver, the transceiver will make a long double beeping tone, the transceivers brand and model will be displayed and the transceiver will enter waiting status.

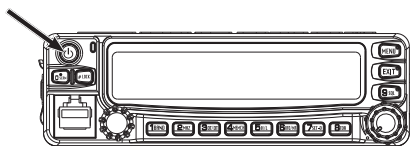

Press the key shown by the arrow



Display brand and model



Enter waiting status

17

**Adjusting the volume**

Rotate the VOL1 and VOL 2 knobs clockwise in order to increase the volume, rotate the knobs counter clockwise to decrease volume, the corresponding volume will be displayed on the LED.

The volume control knobs have upper and lower control devices. The upper control device is the channel and frequency RX volume control on the left side of the screen, the lower level control device is the channel and frequency RX volume control on the right side of the screen.

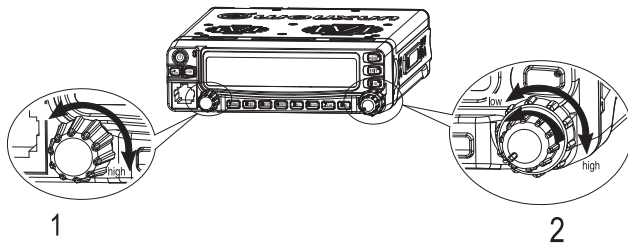

Turn the volume knob clockwise to increase the volume and the RX volume. The maximum volume is level 16. Turn the knob counter-clockwise to decrease the volume and the RX volume. Continue turning the knob counter-clockwise to shut off.

**Selecting Frequency**

(1) Frequency mode(VFO)

VFO Mode is the basic mode for changing the operating frequency, through rotating the TURNING(Tuning) control knobs you can change the operating frequency. Turn the knobs clockwise to increase the frequency and counter-clockwise to decrease. You can also enter the desired frequency using the keypad.

Changing the operating frequency using the keypad:

While in standby mode, press the (2) key to enter in the operating frequency selection. After the LED screen displays 8 whiffle-trees, enter in the 6 figures in order which the frequency will automatically confirm according to the "frequency automated correction" verification. And will then display on the LED screen.

**Automatic frequency correction:**

An operating frequency has a total of 8 digits, the method for verifying the last two digits after inputting 5 digits using the keyboard is as follows:

When the 5th and the 6th are entered in as "31" or "81" the final two digits will be "25".

When the 6th digit is entered in as "0" or "5" the last two digits will be "00".

If the 6th digit is not entered as shown above, it will be automatically corrected to 6.25K step match frequency.

Example frequency 1: 445.95500MHz standby mode:

Press 2 key	Display: [-----,-----]
Input [ 4 ]	Display: [ 4 -----]
Input [ 4 ]	Display: [ 4 4 --,-----]
Input [ 5 ]	Display: [ 4 4 5 ,-----]
Input [ 9 ]	Display: [ 4 4 5 , 9 -----]
Input [ 5 ]	Display: [ 4 4 5 , 9 5 ----]
Input [ 5 ]	Display: [ 4 4 5 , 9 5 0 0 ]

Example frequency 2: 445.56875MHz : standby mode

Press 2 key	Display: [-----,-----]
Input [ 4 ]	Display: [ 4 -----]
Input [ 4 ]	Display: [ 4 4 --,-----]
Input [ 5 ]	Display: [ 4 4 5 ,-----]
Input [ 5 ]	Display: [ 4 4 5 , 5 -----]
Input [ 6 ]	Display: [ 4 4 5 , 5 6 ----]
Input [ 8 ]	Display: [ 4 4 5 , 5 6 8 7 5 ]

## Your first QSO

### (2) Channel mode (CH)

Rotate the (TUNING) control knobs in channel mode to change the operating channel in order to get to the selected operating frequency, or use the keypad to select the operating channel.

Changing the operating channel using the keypad:

In standby mode press the [2] key, at this the time hundredth place of the channel number will appear. After entering the desired hundredth digit, the tenth place digit will appear, after entering the 10th place digit, the single place digit will appear, then enter the desired single place digit of the channel.

Example: Selecting Channel CH-901

In standby mode, after pressing [ 2 ], enter "9", "0", "1" in sequence.

Example: Selecting Channel CH-088

In standby mode, after pressing [ 2 ], enter "0", "8", "8" in sequence

Example: Selecting Channel CH-008

In standby mode, after pressing [ 2 ], enter "0", "0", "8" in sequence

### Selecting output power

While in standby mode, press the [5] key on the front panel or the [5] key on the encoded handheld microphone, to select the output power. Every time the output power is changed, the sequence will be  $\overset{H}{\leftarrow} \overset{M}{\rightarrow} \overset{L}{\leftarrow}$

The transceivers medium output power is M 2, for setup See "Menu3"(MPOW=SET)

Special Reminder: when selecting the output power only do so in relation to the master frequency, See the hotkey operation chart for how to change the master frequency.

## Commonly used basic operations

### TX

(1) In order to transmit signal first grab hold of the handheld microphone, and place about 5 CM away from your mouth, press the [PTT] key, and then speak normally into the microphone. When transmitting, The LED backlight will change to your set color (For TX backlight color settings see instructions on P38), the LED display screen will display a TX-LED indicator light. If you press the PTT key while transmitting outside of the coverage area you will hear an error sound.

(2) Release the [PTT] key, to end transmission.

### Special Reminder

» If the transmission time exceeds the "Menu11(Transmission time-out timer) set time, you will hear a warning indication tone, the transceiver will also stop transmitting and will limit further transmission. After releasing the [PTT] key, the tone will continue for 10 seconds after which the transmission limitation will be lifted. Note: if you press the [PTT] key anytime within the 10 seconds while the tone is sounding, you will hear a warning tone.

### Commonly used basic operations

**Squelch settings:** Press the [9] key, and the muting level will be displayed on the screen, Press the ▼ / ▲ to choose the desired level of muting, to confirm press the [MENU] key.

**Single and dual display:** Press the [8] key in standby mode to select single or dual display.

**Switching modes:** In standby mode, press the [6] key to select VFO frequency mode or MR channel mode. (For detailed operation see hot key 6)

## Shortcut operation chart(See P33-48 for explanation)

Key name	Function Name	Entering hotkey or operation	Remark
<b>1</b> BAND	Master frequency settings	In standby mode, press <b>1</b> BAND to change master frequency	The LED display screen will display a ▼ icon for the master frequency.
<b>2</b> MHZ	Selecting channel or frequency	In standby mode, press <b>2</b> MHZ to enter the Channel or frequency selection.	See operations P29 "selecting frequency" instructions
<b>3</b> QT/DT	CTCSS settings / CTCSS scanner	In standby mode, press <b>3</b> QT/DT to enter the CTCSS selection. In RX mode, press <b>3</b> QT/DT to enter CTCSS scanner.	See operations P29 "CTCSS encoding and decoding" instructions
<b>4</b> MEMCH	Saving channels	In standby mode, press <b>4</b> MEMCH to save a channel.	See operations P29 "Saving channels" instructions
<b>5</b> H/L	Output power level settings	In standby mode, press <b>5</b> H/L to change the output power settings.	Press the desired output power to change level of settings, sequence is as H→M→L
<b>6</b> WFO/MR	Switching frequency mode and channel mode	In standby mode, press <b>6</b> WFO/MR to change the display mode.	See P30 "Switching the display mode"
<b>7</b> SET-D	Frequency direction	In frequency standby mode, press <b>7</b> SET-D Frequency direction settings. In channel standby mode, press <b>7</b> SET-D for reverse frequency or to turn off reverse frequency.	See frequency direction P31 "Frequency direction set up"
<b>8</b> TDR	Single and dual display settings	In standby mode, press <b>8</b> TDR to enter single display or turn off single display.	Only for secondary frequency set up.
<b>9</b> SQL	Squelching level settings	In standby mode, press <b>9</b> SQL to enter squelching level settings.	See P32 "Squelching level setup"
<b>0</b> *SCAN/*SCAN	Scanning function	In standby mode, press <b>0</b> *SCAN/*SCAN to enter the scanning function.	Transceiver panel/Handheld microphone key function
<b>Q</b> SCRAM	Scrambler settings	In standby mode, press <b>Q</b> SCRAM to enter the scrambler settings.	Handheld microphone key settings, see P28 "scrambler settings"
<b>#</b> LOCK	Keypad lock settings	In standby mode, press <b>#</b> LOCK to lock the keyboard or to turn off keyboard lock.	Transceiver panel/Handheld microphone key function

**Note:** Frequency mode and channel mode are of identical operation (Besides independent indication mode).

## Menu Function and operation(See P33-48 for explanation)



Twin Band FM Transceiver

Function Code	Function Name	Enter function set	Screen display	Select parameter	Selectable Parameter Explanation	Confirm	Back	See page
1	Step frequency settings	MENU → <b>1</b> BAND	STEP 001	Press the ▲ key or the ▼ key to choose an index	Keys 1-9 correspond to step frequency: 5.0K, 6.25K, 10.0K, 12.5K, 20.0K, 25.0K, 30.0K, 50.0K, 100.0K	MENU → EXIT		P33
2	Wide/narrow bandwidth settings	MENU → <b>2</b> MHZ	W/N 002	Press the ▲ key or the ▼ key to choose an index	WIDE: wide bandwidth(25K) NARR:narrow bandwidth(12.5K)	MENU → EXIT		P33
3	Medium power settings	MENU → <b>3</b> QT/DT	MPOW-SET 003	Press the ▲ key or the ▼ key to choose an index	MPOW1: 20W MPOW2: 10W	MENU → EXIT		P33
4	Off-set frequency settings	MENU → <b>4</b> MEMCH	OFF-SET 004	Press the ▲ key or the ▼ key to choose an index	Selectable in the range 0-599.995	MENU → EXIT		P34
5	Transmission prompt display settings	MENU → <b>5</b> H/L	ROGER 005	Press the ▲ key or the ▼ key to choose an index	BOT: When the PTT key is pressed, the transmission will prompt. EOT: when the PTT is released, the transmission will prompt. BOTH: When pressing and releasing the PTT key, the transmission will prompt. OFF: Transmission beep will not prompt when off.	MENU → EXIT		P34
6	Beep prompt settings	MENU → <b>6</b> WFO/MR	BEEP 006	Press the ▲ key or the ▼ key to choose an index	ON: Activate beep prompt OFF: Deactivate beep prompt	MENU → EXIT		P34
7	Voice prompt settings	MENU → <b>7</b> SET-D	VOICE 007	Press the ▲ key or the ▼ key to choose an index	CHINESE: Chinese prompts ENGLISH: English prompts OFF: Deactivate voice prompts.	MENU → EXIT		P34
8	Busy channel lockout	MENU → <b>8</b> TDR	BCL 008	Press the ▲ key or the ▼ key to choose an index	ON: Activate BCL function OFF: Deactivate BCL function	MENU → EXIT		P35
9	Squelch settings	MENU → <b>9</b> SQL	SP-MUTE 009	Press the ▲ key or the ▼ key to choose an index	There are three squelch settings: QT&DTMF, QT+DTMF, OFF	MENU → EXIT		P35
10	Scanning settings	MENU → <b>1</b> BAND → <b>Q</b> SCRAM	SC-REV 010	Press the ▲ key or the ▼ key to choose an index	SE: Carrier wave scanning 2 TO: Time scanning CO: Carrier wave scanning 1	MENU → EXIT		P36
11	Transmission time-out timer	MENU → <b>1</b> BAND → <b>1</b> BAND	TOT 011	Press the ▲ key or the ▼ key to choose an index	There are 60 levels on TOT, each corresponding to 1 minute	MENU → EXIT		P36

# Menu Function and operation(See P33-48 for explanation)

12 Transmission overtime alarm	MENU → 1 BAND → 2 MHZ → TOA PH 012 → MENU	Press the ▲ key or the ▼ key to choose an index	There are 1-10 level on TOA, each corresponding to 1 minute OFF: Deactivate TOA	MENU → EXIT P36
13 Caller ID switch	MENU → 1 BAND → 3 QT/DT → ANI-SW PH 013 → MENU	Press the ▲ key or the ▼ key to choose an index	ON: Activate OFF: Deactivate	MENU → EXIT P37
14 Ring time	MENU → 1 BAND → 4 MEMCH → RING PH 014 → MENU	Press the ▲ key or the ▼ key to choose an index	Level 1-10, each corresponding to 1 second OFF: Deactivate	MENU → EXIT P37
15 Editing Caller ID	MENU → 1 BAND → 5 H/L → ANI-EDIT PH 015 → MENU	Press the ▲ key or the ▼ key to choose an index	Individual Caller IDs can be chosen within the range 100-999999, and cannot begin with 0	MENU → EXIT P37
16 Dual-tone sidetone settings	MENU → 1 BAND → 6 WFO/MR → DTMFST PH 016 → MENU	Press the ▲ key or the ▼ key to choose an index	DT-ST: Keypad sidetone will be activated when transmitting ANI-ST: Caller ID sidetone will be activated when transmitting DT-ANI: Caller ID sidetone and keypad sidetone will be activated when transmitting OFF: Deactivate all	MENU → EXIT P38
17 Caller ID transmission mode	MENU → 1 BAND → 7 SET-D → PTT-ID PH 017 → MENU	Press the ▲ key or the ▼ key to choose an index	BOT: Press PTT to transmit caller ID. EOT: Release PTT to transmit caller ID. BOTH: Press and release PTT will both transmit caller ID.	MENU → EXIT P38
18 Transmission backlight	MENU → 1 BAND → 8 TOR → TX-LED PH 018 → MENU	Press the ▲ key or the ▼ key to choose an index	WHITE: White backlight BLUE: Blue backlight GREEN: Green backlight OFF: Deactivate	MENU → EXIT P38
19 Waiting backlight	MENU → 1 BAND → 9 SOL → WT-LED PH 019 → MENU	Press the ▲ key or the ▼ key to choose an index	WHITE: White backlight BLUE: Blue backlight GREEN: Green backlight OFF: Deactivate	MENU → EXIT P39
20 Receiving backlight	MENU → 2 MHZ → 0 SCRAM → RX-LED PH 020 → MENU	Press the ▲ key or the ▼ key to choose an index	GREEN: Green backlight WHITE: White backlight BLUE: Blue backlight OFF: Deactivate	MENU → EXIT P39
21 Deleting a channel	MENU → 2 MHZ → 1 BAND → DEL-CH PH 021 → MENU	Press the ▲ key or the ▼ key to choose an index	There are 999 channels, which the priority channels of 1st and 2nd cannot be deleted.	MENU → EXIT P39
22 Editing channel name	MENU → 2 MHZ → 2 MHZ → CH-NAME PH 022 → MENU	Press the ▲ key or the ▼ key to choose an index	Channel name can be up to 8 digits long and can be made up of upper-case or lower-case letters, numbers, or symbols	MENU → EXIT P39

23 Priority channel switch	MENU → 2 MHZ → 3 QT/DT → PRICH-SW PH 023 → MENU	Press the ▲ key or the ▼ key to choose an index	ON: Activate OFF: deactivate	MENU → EXIT P40
24 Speaker settings	MENU → 2 MHZ → 4 MEMCH → SP-CONT PH 024 → MENU	Press the ▲ key or the ▼ key to choose an index	SPK1: The transceiver-mounted speaker is activated SPK2: The handset speaker is activated SPK1+2: Both the transceiver-mounted speaker and the handset speaker are activated.	MENU → EXIT P40
25 Keypad auto lock	MENU → 2 MHZ → 5 H/L → AUTOLOCK PH 025 → MENU	Press the ▲ key or the ▼ key to choose an index	ON: Activate OFF: deactivate	MENU → EXIT P41
26 RX mode CTCSS set up	MENU → 2 MHZ → 6 WFO/MR → RX-CTC PH 026 → MENU	Press the ▲ key or the ▼ key to choose an index	CTCSS have a total of 50 groups OFF: deactivate	MENU → EXIT P41
27 RX digit CTCSS settings	MENU → 2 MHZ → 7 SET-D → RX-DCS PH 027 → MENU	Press the ▲ key or the ▼ key to choose an index	CTCSS digits have a total of: 105 groups of code, 105 of anti-code OFF: deactivate	MENU → EXIT P41
28TX CTCSS set up	MENU → 2 MHZ → 8 TOR → TX-CTC PH 028 → MENU	Press the ▲ key or the ▼ key to choose an index	CTCSS have a total of 50 groups OFF: deactivate	MENU → EXIT P41
29 TX digit CTCSS settings	MENU → 2 MHZ → 9 SOL → TX-DCS PH 029 → MENU	Press the ▲ key or the ▼ key to choose an index	CTCSS digits have a total of: 105 groups of code, 105 of anti-code OFF: deactivate	MENU → EXIT P41
30 Repeater speaker switch	MENU → 3 QT/DT → 0 SCRAM → RPT-SPK PH 030 → MENU	Press the ▲ key or the ▼ key to choose an index	ON: Speaker is activate when repeating OFF: Speaker is deactivate when repeating	MENU → EXIT P42
31 Repeater PTT switch	MENU → 3 QT/DT → 1 BAND → RPT-PTT PH 031 → MENU	Press the ▲ key or the ▼ key to choose an index	ON: PTT transmission activated when repeating OFF: PTT transmission blocked when repeating	MENU → EXIT P42
32 Repeater settings	MENU → 3 QT/DT → 2 MHZ → RPT-SET PH 032 → MENU	Press the ▲ key or the ▼ key to choose an index	X-DRPT: Single cross band repeat X-TWRPT: Twin cross band repeat CRPT-RX: Repeater Reception CRPT-TX: Repeater Transmission RADIO: Transceiver mode	MENU → EXIT P43
33 Scan add	MENU → 3 QT/DT → 3 QT/DT → SCAN ADD PH 033 → MENU	Press the ▲ key or the ▼ key to choose an index	ON: When scanning channels, they will be added to the scanning table OFF: Channels will not be added to the table when scanning	MENU → EXIT P44
34 Automatic power-off	MENU → 3 QT/DT → 4 MEMCH → APO TIME PH 034 → MENU	Press the ▲ key or the ▼ key to choose an index	Levels 1-5, each level corresponding to 30-minute. OFF: Deactivate automatic power-off	MENU → EXIT P45

## Menu Function and operation(See P33-48 for explanation)

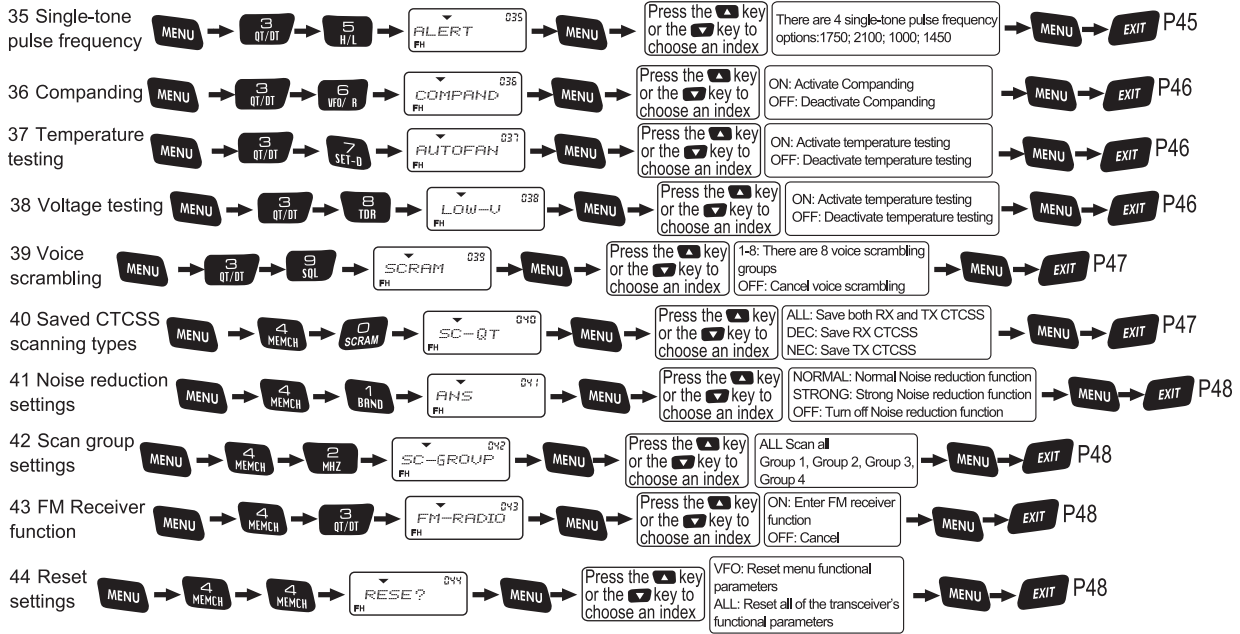

26

## Function description

Wouxun

Twin Band FM Transceiver

### I. The vehicle transceiver has multiple functions:

- (1) Work mode of transceiver
- (2) Cross-band repeater work mode
- (3) Repeater receiver and repeater transmitter operating mode.

Note: Can be set through Menu32 (See P43 instructions).

(1) The vehicle transceiver control panel LED Is divided into two display settings, A and B, displaying the two vehicle transceiver operating frequencies.

The master frequency will be indicated by “▼”. This icon is very important. All Operating instructions are all concerning the master frequency indicated by this icon. If the frequency does not have the “▼” icon, it will be called a secondary frequency. The master and secondary frequency will be separated by a vertical bar on the display device.

(2) While the vehicle transceiver is in operating mode, only one channel can be set to the FM receiver ( 65-108MHz ) function.

(3) The vehicle transceiver's two operating channels parameters can be set. Before changing the parameter settings, first set the desired channel to the master frequency.

( Master frequency settings see P28 “Master frequency settings” )

(4) When the vehicle transceiver is operating in cross-band repeater mode, or repeater reception/ repeater transmission mode, some Transceiver functions will be prohibited.

## Hotkey function guide



### II. Hotkey function guide.

The settings menu is divided into quick start and operating menu settings, and aside from their shared operating settings, all of the functional operations of work areas A and B are oriented at the master frequency.

#### Special Reminder





» The vehicle transceiver operating frequency parameters can be separately set. (Example: STEP step frequency, W/N Wide/narrow bandwidth frequency, VFO/MR display mode, OFF-SET off set frequency, BCL busy channel lockout, SP-MUTE squelch mode operations) As well as System parameters ( Example: RX-LED receiver backlight color function etc.) are AB's two operational channels. When setting the main frequency you all change the system parameters.

#### ■ Rapid Search Function

When using the device or setting any functional parameters you can search the data above or below it by pressing the  or  keys.

#### (I) Quick operation

##### (0) Voice scrambler function key(Optional)

When the machine is standby, press the  key to enter voice scrambling settings, then press the  /  key or a number from 1-8 to choose a voice scrambling group, and press the  key to confirm, exit settings and return to standby. Voice scrambling has a total of 1 – 8 groups, OFF Shuts down the voice scrambling function. If the vehicle transceiver does not come with this option, pressing this key will be of no effect!

##### (1) BAND Master frequency settings hotkey

When the transceiver is standby, press the  key on the handset or transceiver to switch between master frequency and secondary frequency.

#### Special Reminder

» When the A or B Areas or the display screen display an “▼” icon, this indicates that that area is the master frequency, and the other areas are secondary frequency, this icon is very important, all of the functional operations are oriented at the master frequency.

#### (2) MHZ Frequency selection or channel selection hotkey

■ When the transceiver is standby (in frequency mode), press the  key to enter frequency settings, and 8 whiffletrees will appear, please input another 6 values from the keyboard, which the frequency will automatically confirm. The standards for automatic recognition are:

- (1) When the 6th digit is less than or equal to 4, the final frequency's 6th, 7th and 8th digits are 0.
  - (2) When the 6th digit is 5, the final frequency's 6th digit is 5, the 7th and 8th digits are 0.
  - (3) When the 6th digit is equal to or greater than 6, the final frequency will be based on the total factor of the 5th and 6th digits into 625.
- If any keys other than 0-9 are pressed when inputting the 5-digit number, the frequency settings will be exited.

#### (3) D-SCAN CTCSS scanning key

This key has two functions, when the transceiver is in standby mode it is an CTCSS encoder and decoder function, and when the transceiver is in RX mode it is an CTCSS scanner. (The CTCSS scanning function is only effective in Transceiver operation mode, in Cross-band repeat or repeater reception mode / transmission mode it is ineffective).

■ When the transceiver is standby (channel mode), press the  key on the transceiver or handset to enter selective channel calling settings, at which point the LCD screen will display "CH-XXX" (the code of the present channel), and the channel will blink. Enter the required selective channel to make a selective call to this channel; if the input channel has not been set up, you will be returned to the previously-set channel.

#### A. CTCSS encoding and decoding settings

The CTCSS encoding and decoding settings simultaneously set the channel RX CTCSS (decoding) and TX CTCSS (encoding) settings.

## Hotkey function guide

To set the Encoding and decoding functions separately see MENU 26-29 operating instructions.

In standby mode, press **[3 07/01]** key to select CTCSS or CDCSS, the LCD will display: **1CTC&2DT**

Press **[1 BRAND]** key to enter CTCSS ( CTCSS ) settings / press the **[2 MHZ]** key to enter CDCSS ( DCS ) settings / After entering the settings, press the **[▲]** / **[▼]** keys to choose the needed group, press the **[MENU]** key to confirm.

### B. CTCSS scanner function

When the vehicle transceiver is in RX mode, press the **[3 07/01]** key to enter select the CTCSS or CDCSS scanning function, the LCD will then display: **1CTC&2DT**

Press the **[1 BRAND]** key to choose the CTCSS scanner / press the **[2 MHZ]** key to choose the CDCSS scanner, once the scanner is set correctly, the CTCSS will remain displayed on the LCD screen, press the **[MENU]** key to save the channel to the corresponding CTCSS parameters. Save the parameters according to Menu 40 instructions.

### (4) MEM-CH Save channel hotkey

When the present operating channel is in channel mode (MR), save all parameters of the channel besides that of the channel name.

When the present operating channel is in Frequency mode (VFO) you can set different off-set frequencies (for off-set frequency settings see Menu functions 4) as well as off-set frequency orientation (for frequency orientation settings see hotkey operations 7) as well as saving other channel parameters. This way you can set up same-band or different-band channels

In standby mode, press the **[4 MEM-CH]** key to enter saved channel at this time the LCD will display: **CH-001 004**

Enter the Hundredths place tenths place and single place of the desired channel in sequence to save the channel. Press the **[MENU]** to confirm.

### (5) H/L Output power settings switch key

H/L function key, is an output power switch hotkey

When the transceiver is standby, the **[5 RL]** key will quickly switch power; every time **[5 RL]** the key is pressed, the power will shift in the following direction: High power (H) → Medium power (M) → Low power (L)



30

Medium output power has two levels. for detailed functions see Menu3 "two medium level output power" instructions

### (6) VFO/MR Frequency/Channel switch hotkey

The vehicle transceiver operating channel can be set as VFO Frequency mode and MR channel mode, Amongst those MR channel mode has three different display types.

A. Channel number mode B. Channel frequency+Channel display mode C. Channel name display mode. The VFO Frequency mode and MR channel mode sometimes are setup with passcode limitations; they need a correct password in order to be able to switch between the two. However the MR channel mode does not need a passcode to switch between the 3 different display modes.

VFO/MR"(Frequency/Channel switch) switching is shown below:



When the setup is setup with a switch passcode, press the **[6 VFO/MR]** key, The LCD will display: **-----**

At this time enter a 6 digit passcode, if the passcode is correct the mode will switch successfully, If the passcode is incorrect the mode switch will be ineffective, a double tone will follow and you will exit the program. The only way to set up the passcode is through our companies supplied software. If 6 0's are entered this will turn off the password function.

### (7) SET-D Off-set frequency orientation switch hotkey

● In FM mode, press the **[7 SET-D]** key to rapidly switch orientation rapidly as shown below:

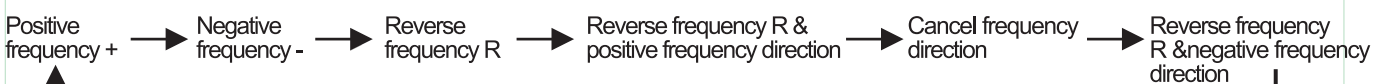

When rapidly switching frequencies, the frequency direction will be skipped automatically if the frequency direction results in frequency error.

● In channel mode, press the **[7 SET-D]** key this will only set "reverse frequency R" or "turn off reverse frequency R" function.

This function can be prohibited while the vehicle transceiver is in cross-band repeater or repeater receiver or repeater transmitter mode.

## Hotkey function guide





### (8) TDR Single or dual display switch hotkey

When in standby, press the  key, and you can switch between single and dual display.

This function can be prohibited while the vehicle transceiver is in cross-band repeater or repeater receiver or repeater transmitter mode.

### (9) Squelch level settings hotkey

The SQL function rapidly switches between squelching settings.

When in standby, press the  key and the muting level in the area will be displayed on the screen, then press  /  or directly press 0-9 to choose the desired level of muting, press  to confirm, then press  to exit settings.

### (10) SCAN Scanner key



In standby mode, press the handheld microphone  key or the panel  key, to start scanning. Frequency mode will start scanning by "step frequency" in intervals, channel mode will start scanning in the current channel, press the  /  keys while scanning to change the scanning direction (higher or lower), press any key to stop scanning. Please see menu 10 SC-REV Scan settings for details of scan types.

This function can be prohibited while the vehicle transceiver is in cross-band repeater or repeater receiver or repeater transmitter mode.



### (11) # Keypad lock key.

When the transceiver is standby, press the  key locks the keyboard. When the keyboard is locked, both the keypad on the handset and the keypad on the front panel are locked.

### (12) Up key

- In frequency mode, press the  key to set a new frequency: "current frequency" + "step frequency".
- In channel mode, press the  key to designate one channel as the working channel.

### (13) down key

- In frequency mode, press the  key to set a new frequency: "current frequency" + "step frequency".
- In channel mode, press the  key to designate one channel as the working channel.

### (14) confirmation key

 key is a confirmation key, as well as a key to enter Menu function setup hotkey.

32

## Menu operation instructions

Wouxun

Twin Band FM Transceiver







### Menu Operations

#### Step frequency setup(STEP) - Menu1

When the transceiver is standby, press the  +  keys and the screen will display: 





Press the  key to access the menu, and after pressing the  /  key to select the required step frequency type, press the  key to confirm, and the  key to return to standby.

This transceiver has 9 types of step frequency: 5KHz, 6.25K, 10KHz, 12.5KHz, 20KHz, 25KHz, 30KHz, 50KHz, 100KHz.

Press the menu  key then press the  key to access the menu, and after pressing the  /  key to select the required step frequency type, press the  key to confirm, and the  key to return to standby.

#### Wide/Narrow bandwidth setup(W/N) - Menu2





When the transceiver is standby, press the  +  keys and the screen will display: 

Press the  key, then Press the  /  keys to choose the desired wide/narrow bandwidth set up and press the  key to confirm. Press the  key to return to standby mode.

This transceiver's bandwidth settings are divided into: wide bandwidth (25KHz) and narrow bandwidth (12.5K).

#### Two Medium power settings ( MPOW-SET ) —Menu3

When the transceiver is standby, press the  +  keys and the screen will display: 

Press the  key, then press the  /  to choose the required output level, and press the  key to confirm. Press the  key to return to standby mode.

This transceiver has two medium power set ups separated as MPOW1:20W ; MPOW2:10W.

### Special Reminder

- » Medium output power settings is a system setting, after changing these settings, the vehicle transceivers two operating frequencies medium output power settings will simultaneously be set.

33

## Menu function operating settings

### Off-set frequency settings(OFF-SET) - Menu4

When the transceiver is standby, press the **MENU** + **4** keys and the screen will display: 

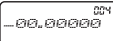
Press the **MENU** key to access the menu, and the screen will display: 

And the first digit will simultaneously flash, after inputting the required offset frequency or pressing the **▲** / **▼** keys to increase or reduce the offset frequency, press the **MENU** key to confirm, and press the **EXIT** key to return to standby.

The transceiver's frequency range is from 0-599.99500MHz, and the KHz of input offset frequency will be automatically confirmed by step frequency. This function can be prohibited while the vehicle transceiver is in cross-band repeater or repeater receiver or repeater transmitter mode.

### TX indication tone settings ( ROGER ) - Menu5

When the transceiver is standby, press the **MENU** + **5** keys and the screen will display: 

Press the **MENU** key to access the menu, and after pressing the **▲** / **▼** keys to choose the required prompt mode, press the **MENU** key to confirm, or the **EXIT** key to return to standby.

The transceiver features 4 kinds of prompt: BOT (beginning of transmission), EOT (end of transmission), BOTH (beginning and end of transmission), and OFF (prompts deactivated).

ROGER Dual tone prompt method, can be set through the supplied programming software. It can be set through (at most 6 digit number) as well as remaining mode or in intervals. ( See programming software for help)

### Beep tone settings(BEEP) - Menu6

When the transceiver is standby, press the **MENU** + **6** keys and the screen will display: 

Press the **MENU** key to access the menu, and after pressing the **▲** / **▼** keys to choose the required voice prompt to confirm, press the **EXIT** key to return to standby mode.

The transceiver has 2 Beep Prompt modes: ON or OFF

### Voice prompt settings(VOICE) - Menu7

When the transceiver is standby, press the **MENU** + **7** keys and the screen will display: 

Press the **MENU** key to access the menu, and after pressing the **▲** / **▼** keys to choose the required prompt mode, press the **MENU** key to confirm,

34

or the **EXIT** key to return to standby.

This transceiver has 3 voice prompt settings: CHINESE, ENGLISH, and OFF.

## Special Reminder

>> If you need to turn all prompts off, you must turn off both the setting of voice prompt (Menu 7) and the beep prompt (Menu 6).

### Busy channel lockout(BCL) - Menu8

When the transceiver is standby, press the **MENU** + **8** keys and the screen will display: 

Press **MENU** the key to access the menu, and after pressing the **▲** / **▼** keys to choose the required prompt mode, press the **MENU** key to confirm, or the **EXIT** key to return to standby.

The transceiver has 2 BCL modes: ON (activate) and OFF (deactivate).

### Squelch settings(SP-MUTE) - Menu9

When the transceiver is standby, press the **MENU** + **9** keys and the screen will display: 

Press **MENU** the key to access the menu, and after pressing the **▲** / **▼** keys to choose the required prompt mode, press the **MENU** key to confirm, or the **EXIT** key to return to standby.

Squelch settings: set the conditions which determine when the speaker shall be turned on, these settings are used during selective calling, group calling and all calling.

The Transceiver's Squelch Modes Include:

CTCSS (continuous tone controlled squelch system): when the transceiver is set to this mode, all signals on the same CTCSS frequency will activate the speaker.

CTCSS+DTMF(continuous tone controlled squelch + dual-tone multi-frequency signal): only those signals which both satisfy the requirements of CTCSS mode and whose dual-tone multi-frequency carrier wave signal also match the transceiver will activate the speaker in this mode.

CTCSS&DTMF (continuous tone controlled squelch or dual-tone multi-frequency signal): When this mode is active, only those signals which either meet CTCSS requirements or DTMF requirements will activate the speaker.

## Menu operations

### Scan Mode (SC-REV) - Menu 10

When the transceiver is standby, press the **MENU** + **1 BAND** + **0 SCRAM** keys and the screen will display:



Press the **MENU** key to access the menu, and after pressing the **▲** / **▼** keys to select the required setting, press the **MENU** key to confirm, and the **EXIT** key to return to standby.

The transceiver has 3 scan modes: TO, CO, and SE:

TO: after finding a carrier wave signal, scanning will continue if no operations are carried out within 5 seconds.

CO: scanning will stop when a carrier wave signal has been found, and scanning will continue if the carrier wave signal is lost for 3 seconds.

SE: scanning will stop when a carrier wave signal is found.

### Transmission Time-out Timer (TOT) - Menu 11

When the transceiver is standby, press the **MENU** + **1 BAND** + **1 BAND** keys and the screen will display:



Press the **MENU** key to access the menu, and after pressing the **▲** / **▼** keys to select the required time, press the **MENU** key to confirm, and the **EXIT** key to return to standby.

The TOT can be set for up to 60 minutes, 1 level of the setting corresponding to 1 minute.

### Transmission Overtime Alarm (TOA) - Menu 12

When the transceiver is standby, press the **MENU** + **1 BAND** + **2 MRZ** keys and the screen will display:

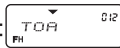

Press the **MENU** key to access the menu, and after pressing the **▲** / **▼** keys to select the required time, press the **MENU** key to confirm, and the **EXIT** key to return to standby.

The TOA has a maximum length of 10 seconds, each level corresponding to 1 second. OFF: Deactivate TOA.

## Special Reminder

- » When the transmission time exceeds the "Time-out timer" set time, a continuous error tone will prompt, release the [PTT] key to stop it. The transmission function will be stopped for 10 seconds and it can not transmit by pressing the [PTT] key, simultaneously a double tone will prompt. After 10 seconds, the transmission function will be restored (Transmission time-out punishment).

36

### Caller ID Transmission Settings (ANI-SW) - Menu 13

When the transceiver is standby, press the **MENU** + **1 BAND** + **3 0/7H** keys and the screen will display:

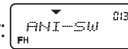

Press the **MENU** key to access the menu, and after pressing the **▲** / **▼** keys to select the required setting, press the **MENU** key to confirm, and the **EXIT** key to return to standby.

Caller ID transmission: ON activate, OFF deactivate.

### Ring Time (RING) — Menu 14

When the transceiver is standby, press the **MENU** + **1 BAND** + **4 MEMO** keys and the screen will display:



Press the **MENU** key to access the menu, and after pressing the **▲** / **▼** keys to select the required time, press the **MENU** key to confirm, and the **EXIT** key to return to standby.

The transceiver has 10 levels of ring time, each corresponding to 1 second. OFF: ring deactivated.

### Editing Caller ID (ANI-EDIT) - Menu 15

The transceiver's caller ID is composed of the Arabic numerals 0-9: the first digit cannot be 0, and ID numbers can be as short as 3 digits and as long as 6.

When the transceiver is standby, press the **MENU** + **1 BAND** + **5 H/L** keys and the screen will display:



Press the **MENU** key to access the settings menu, and after inputting the required digits, press the **MENU** key to confirm, and the **EXIT** key to return to standby.

Example 1: editing a 6-digit caller ID number (901285)

When the transceiver is standby, press the **MENU** + **1 BAND** + **5 H/L** keys and the screen will display:

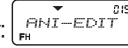

After pressing the **MENU** key, the first digit will flash, then input the required value **9 SQL** **0 SCRAM** **1 BAND** **2 MRZ** **8 TDR** **5 H/L**

Press the **MENU** key to confirm, and press the **EXIT** key to return to standby.

Example 2: editing a 3-digit caller ID number (901)

When the transceiver is standby, press the **MENU** + **1 BAND** + **5 H/L** keys and the screen will display:

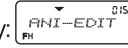

## Menu operations

After pressing **MENU** the key, if a caller ID number has already been input, it will be displayed, and the first digit will flash. If no caller ID number has been input, 101 will be displayed, and the first digit will flash, input **9** **SCRAM** **1** **BAND**, and after the third digit has been input, the symbol "<" will flash in the 4th digit, press the **MENU** key to confirm, and the **EXIT** to return to standby.

### Special Reminder

>> Each transceiver can have only one caller ID number, which is shared by Areas A and B.

#### Dual-Tone Side-Tone Settings (DTMFST) - Menu 16

When the transceiver is standby, press the **MENU** + **1** **BAND** + **6** **VEB/MT** keys and the screen will display: 

Press the **MENU** key to access the menu, and after pressing the **▲** / **▼** keys to select the required setting, press the **MENU** key to confirm, and the **EXIT** key to return to standby.

The transceiver has the following DTFMF modes; DT-ST: Keypad sidetone will be activated when transmitting ANI-ST: caller ID sidetone will be activated when transmitting DT+ANI: keypad and caller ID sidetone are both activated when transmitting.

#### Caller ID Transmitter mode (PTT-ID)- Menu 17

When the transceiver is standby, press the **MENU** + **1** **BAND** + **7** **SETU** keys and the screen will display: 

Press the **MENU** key to access the menu, and after pressing the **▲** / **▼** keys to select the required setting, press the **MENU** key to confirm, and the **EXIT** key to return to standby.

The transceiver features 3 kinds of ID: BOT (beginning of transmission), EOT (end of transmission), BOTH (beginning and end of transmission).

#### Transmission Backlight (TX-LED)- Menu 18

When the transceiver is standby, press the **MENU** + **1** **BAND** + **8** **TRH** keys and the screen will display: 

Press the **MENU** key to access the menu, and after pressing the **▲** / **▼** keys to select the required backlight color, press **MENU** the key to confirm, and **EXIT** the key to return to standby.

The transceiver has 3 backlight colors: BLUE; GREEN; WHITE; OFF: Deactivate.

38

 Wouxun

Twin Band FM Transceiver

#### Waiting Backlight (WT-LED)- Menu 19

When the transceiver is standby, press the **MENU** + **1** **BAND** + **9** **SIL** keys and the screen will display: 

Press **MENU** the key to access the menu, and after pressing the **▲** / **▼** keys to select the required backlight color, press **MENU** the key to confirm, and **EXIT** the key to return to standby.

The transceiver has 3 backlight colors: BLUE; GREEN; WHITE; OFF: Deactivate.

#### Receiving Backlight (RX-LED)- Menu 20

When the transceiver is standby, press the **MENU** + **2** **MRZ** + **0** **SCRAM** keys and the screen will display: 

Press **MENU** the key to access the menu, and after pressing the **▲** / **▼** keys to select the required backlight color, press **MENU** the key to confirm, and **EXIT** the key to return to standby.

The transceiver has 3 backlight colors: BLUE; GREEN; WHITE; OFF: Deactivate.

#### Deleting a Channel (DEL-CH) - Menu 21

When the transceiver is standby, press the **MENU** + **2** **MRZ** + **1** **BAND** keys and the screen will display: 

Press the **MENU** key to access the menu, and after pressing the **▲** / **▼** to select the channel you wish to delete or manually inputting the channel code, press the **MENU** key to confirm and the **EXIT** key to return to standby.

### Special Reminder

>> The 1st, 2nd and the Priority Channels are fixed channels and cannot be deleted.

#### Editing a Channel Name (CH-NAME) - Menu 22

Channel names can only be edited in channel mode, and only the name of the present channel can be edited- this operation is ineffective in frequency mode.

When the transceiver is standby, press the **MENU** + **2** **MRZ** + **2** **MRZ** keys and the screen will display: 

Press the **MENU** key to access the menu, and the first digit will flash (which indicates that this digit is being edited)

39

## Menu operations

Press the **#** key to switch character sets (this switches between special characters, upper-case letters, lower-case letters, and numbers), press the **▲** key to choose the required character, press **▼** to edit the next character, and press **\* SCAN** to clear the character you are currently editing. When you have finished editing the name, press **MENU** to confirm, and press **EXIT** to exit the editing screen.

Note: 1.Channel names can be a maximum of 8 characters long, and the first character may not be 0.

2.When all 8 characters are empty, the channel will be displayed on the screen as CH-\*\*\* (\*\* being the channel's code).

### Priority Channel Switch (PRICH-SW) - Menu 23

When the transceiver is standby, press the **MENU** + **2 MRZ** + **3 SW** keys and the screen will display: 

Press the **MENU** key to access the settings, and after pressing the **▲** / **▼** key to activate or deactivate the speaker, press the **MENU** to confirm, and press the **EXIT** key to return to standby

The priority channel switch can be set to ON or OFF. OFF: selectable

## Special Reminder

>> While in frequency mode or channel mode, you only need to turn on the priority channel, and the priority channel will scan in 3 second intervals. The priority channel is only used when receiving, if you need to transmit, please set the priority channel as the present channel.

### Speaker Settings (SP-CONT) - Menu 24

When the transceiver is standby, press the **MENU** + **2 MRZ** + **4 SP-CONT** keys and the screen will display: 

Press the **MENU** key to access the menu, and after pressing the **▲** / **▼** keys to select the desired setting, press the **MENU** key to confirm, and press the **EXIT** key to return to standby.

There are 3 speakers on the transceiver, 2 are for the transceiver that is separated by Area A/B and 1 is for handset speaker. You can activate the handset speaker as the only one speaker. You can also both activate the transceiver and handset speaker.

SPK1: only the transceiver unit speaker is activate.

SPK2: only the handset speaker is activate.

SPK1+SPK2: the transceiver-mounted speaker and the handset speaker are both activate.

40

### Keypad AutoLock - Menu 25

When the transceiver is standby, press the **MENU** + **2 MRZ** + **5 A/L** keys and the screen will display: 

Press the **MENU** key to access the menu, and after pressing the **▲** / **▼** keys to select the desired setting, press the **MENU** key to confirm, and press **EXIT** the key to return to standby.

### Receive CTCSS settings (RX-CTC) — Menu 26

When the transceiver is standby, press the **MENU** + **2 MRZ** + **6 RX-CTC** keys and the screen will display: 

Press the **MENU** key to access the menu, and after pressing the **▲** / **▼** key to select the CTCSS you desire, press the **MENU** key to confirm, and press the **EXIT** key to return to standby.

The CTCSS has a total of 50 groups, OFF: Deactivate

### Receiver CDCSS settings (RX-DCS) - Menu 27

When the transceiver is standby, press the **MENU** + **2 MRZ** + **7 RX-DCS** keys and the screen will display: 

Press the **MENU** key to access the menu, and after pressing the **▲** / **▼** key to select the CDCSS you desire, press the **MENU** key to confirm, and press the **EXIT** key to return to standby.

CDCSS: 105 groups of code, 105 groups of anti-code; OFF: Deactivate.

### Transceiver CTCSS settings (TX-CTC) - Menu 28

When the transceiver is standby, press the **MENU** + **2 MRZ** + **8 TX-CTC** keys and the screen will display: 

Press the **MENU** key to access the menu, and after pressing the **▲** / **▼** key to select the CTCSS you desire, press the **MENU** key to confirm, and press the **EXIT** key to return to standby.

CTCSS has a total of 5 groups; OFF: Deactivate.

### Transceiver CDCSS settings(TX-DCS) - menu 29

When the transceiver is standby, press the **MENU** + **2 MRZ** + **9 TX-DCS** keys and the screen will display: 

Press the **MENU** key to access the menu, and after pressing the **▲** / **▼** key to select the CDCSS you desire, press the **MENU** key to confirm, and press the **EXIT** key to return to standby.

## Menu operations

CDCSS: 105 groups of code, 105 groups anti-code; OFF: Deactivate.

1	67.0	11	94.8	21	131.8	31	171.3	41	203.5
2	69.3	12	97.4	22	136.5	32	173.8	42	206.5
3	71.9	13	100.0	23	141.3	33	177.3	43	210.7
4	74.4	14	103.5	24	146.2	34	179.9	44	218.1
5	77.0	15	107.2	25	151.4	35	183.5	45	225.7
6	79.7	16	110.9	26	156.7	36	186.2	46	229.1
7	82.5	17	114.8	27	159.8	37	189.9	47	233.6
8	85.4	18	118.8	28	162.2	38	192.8	48	241.8
9	88.5	19	123.0	29	165.5	39	196.6	49	250.3
10	91.5	20	127.3	30	167.9	40	199.5	50	254.1

1	D023N	16	D074N	31	D165N	46	D261N	61	D366N	76	D462N	91	D627N
2	D025N	17	D114N	32	D172N	47	D263N	62	D364N	77	D464N	92	D631N
3	D026N	18	D115N	33	D174N	48	D265N	63	D365N	78	D465N	93	D632N
4	D031N	19	D116N	34	D205N	49	D266N	64	D371N	79	D466N	94	D645N
5	D032N	20	D122N	35	D212N	50	D271N	65	D411N	80	D503N	95	D654N
6	D036N	21	D125N	36	D223N	51	D274N	66	D412N	81	D506N	96	D662N
7	D043N	22	D131N	37	D225N	52	D306N	67	D413N	82	D516N	97	D664N
8	D047N	23	D132N	38	D226N	53	D311N	68	D423N	83	D523N	98	D703N
9	D051N	24	D134N	39	D243N	54	D315N	69	D431N	84	D526N	99	D712N
10	D053N	25	D143N	40	D244N	55	D325N	70	D432N	85	D532N	100	D723N
11	D054N	26	D145N	41	D245N	56	D331N	71	D445N	86	D546N	101	D731N
12	D065N	27	D152N	42	D246N	57	D332N	72	D446N	87	D565N	102	D732N
13	D071N	28	D155N	43	D251N	58	D343N	73	D452N	88	D606N	103	D734N
14	D072N	29	D156N	44	D252N	59	D346N	74	D454N	89	D612N	104	D743N
15	D073N	30	D162N	45	D255N	60	D351N	75	D455N	90	D624N	105	D754N

### Repeater Speaker Switch (RPT-SPK) - Menu 30

When the transceiver is standby, press the **MENU** + **3** **BT/IT** + **0** **SCRAM** keys and the screen will display: 

Press the **MENU** key to access the settings, and after pressing the **▲** / **▼** key to activate or deactivate the speaker, press the **MENU** to confirm, and press the **EXIT** key to return to standby

During repeating, you can select the following options for the speaker key: ON (active) OFF (inactive)

### Repeater PTT Switch (RPT-PTT)- Menu 31

When the transceiver is standby, press the **MENU** + **3** **BT/IT** + **1** **BAND** keys and the screen will display: 

Press the **MENU** key to access the settings, and after pressing the **▲** / **▼** key to activate or deactivate the speaker, press the **MENU** to confirm, and press the **EXIT** key to return to standby

During repeating, you can select the following options for the PTT transmission key: ON (active) OFF (inactive)

### Repeater settings(RPT-SET) - Menu32

There are 5 modes in the repeater settings menu: RADIO transceiver mode, X-DIRPT cross band directional repeat mode, X-TWRPT twin cross band repeat mode, CRPT-RX repeater reception mode and CRPT-TX repeater transmission mode.

When the vehicle-mounted transceiver is in transceiver mode, you can either directly enter the cross band repeat or repeat mode or return to transceiver mode from cross band repeat or repeat mode by setting the menu.

The conditions set to directional or twin directional cross-band repeat:

The two working channels of vehicle-mounted transceiver must be two cross-bands or channels. For example, the RX frequency for area A is at UHF frequency and the B is at VHF frequency.

And vice versa.

Directional cross-band repeater: the master frequency is set to the repeater receiver, the secondary frequency is set to the repeater transmitter; the receiver is only responsible for receiving, the transmitter is only responsible for transmission.

Twin cross-band repeater: when the transceiver is standby\*the master and secondary frequency are both repeater transceiver. If the master frequency first receives an effective carrier wave signal, the secondary frequency will automatically be set to the cross-band repeat transmitter and vice versa.

The twin cross-band repeat receiver and transmitter are not fixed. The first received is receiver and relatively the other one is transmitter.

Cross-band repeat RX,TX frequency and CTCSS encoding and decoding settings:

- 1.VFO mode is RX, TX frequency that receive the RX frequency as the cross band repeat;
- 2.MR mode is RX, TX frequency that receive the RX frequency of current channel as the cross-band repeat;
- 3.Cross band repeat RX CTCSS (decoding) is based on the receiver CTCSS (decoding) as cross-band repeat.

Cross-band repeater or repeater settings can be set through menus 30 (RPT-SPK) and menu31 (RPT-PTT). Selecting repeater/relay repeater receiver tone whether the transceiver speakers are on or whether the [PTT] key is being pressed on the repeater or relay transmission. But when the PTT is transmitting, the repeater or the relay signal will be temporarily interrupted.

## Menu operations

When the transceiver is standby, press the **MENU** + **9** (RT) + **2** (MRZ) keys and the screen will display:

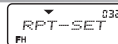

Press the **MENU** key to enter settings, press the **▲** / **▼** key to select the required type:

### Special Reminder

» In cross-band repeater mode, the middle of the screen will display . When relay transceiver is in transmitter/receiver mode, the screen will display .

#### Connecting the relay receiver and transmitter:

Through 32RPT-SET menu settings, we can separately set the two vehicle-mounted transceivers as relay receiver and transmitter. To create a relay station, connect two transceivers marked as PC facet block by using an 8-core facet cable separately.

The 8-core facet cable is an optional accessory.

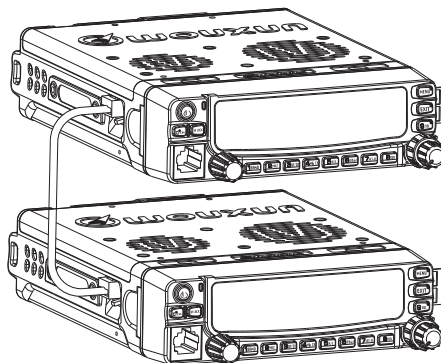

#### Scan Add (SCANADD) - Menu 33

Scan add determines whether a given channel is added after scanning. As a result, this function can only be used in channel mode, can only be used with the present channel, and is ineffective in frequency mode.

44

 Wouxun

Twin Band FM Transceiver

When the transceiver is in channel mode, press the **MENU** + **9** (RT) + **9** (RT) keys and the screen will display:

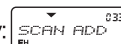

Press the **MENU** key to access the menu, and after pressing the **▲** / **▼** keys to select the required parameter, press the **MENU** key to confirm, and the **EXIT** key to return to standby.

Scan Add has 2 parameters: ON (add), OFF (cancel).

#### Automatic power-off (APOTIME) - Menu 34

When the transceiver is standby, press the **MENU** + **9** (RT) + **4** (MEMO) keys and the screen will display:

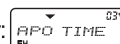

Press the **MENU** key to access the settings menu, and after pressing the **▲** / **▼** keys to select the desired parameters, press the **MENU** key to confirm, and the **EXIT** key to return to standby.

If the transceiver undertakes no operations, and does not receive or transmit any signals within a set period of time, the Automatic Power off function will automatically power the transceiver off.

There are 5 kinds of automatic power off in total: 30 seconds, 60 seconds, 90 seconds, 120 seconds, and 150 seconds. OFF: Turning off the automatic power off is prohibited in repeater or relay mode.

#### Single-tone Pulse Frequency (ALERT)- Menu 35

Some of the relay systems used for single-tone pulse transmission need a single-tone pulse signal to activate, if a repeater is already active, however, this signal is not needed. The following pulse signal frequencies can be selected: 1750HZ, 2100HZ, 1000HZ, 1450HZ.

When the transceiver is standby, press the **MENU** + **9** (RT) + **5** (M) keys and the screen will display:

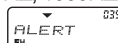

Press the **MENU** key to access the menu, and after pressing the **▲** / **▼** keys to select the desired parameter, press the **MENU** key to confirm, and the **EXIT** key to return to standby.

### Special Reminder

» When in transmitter mode, you can send the single-tone pulse frequency you've selected by pressing key "1" on the panel.

## Menu operations

### Compand - Menu 36

The compand function effectively minimizes noise, and its results are especially evident when transmitting over long distances.

When the transceiver is standby, press the **MENU** + **3** (QT/OT) + **6** (WR/WR) keys and the screen will display:

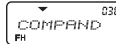

Press the **MENU** key to access the menu, and after pressing the **▲** / **▼** keys to select the desired parameter, press the **MENU** key to confirm, and the **EXIT** key to return to standby.

There are two kinds of compand: ON (activate), OFF (deactivate).

### Overheating detection (AUTOFAN) - Menu 37

Overheating detection: the vehicle transceiver has a built-in temperature detection system that will activate a cooling fan whenever the temperature reaches a pre-set amount depending on if this mode is activated. (ON: The transceiver will automatically turn on a cooling fan when the temperature reaches a set amount, and will stop once it has cooled down. Off: turns off this setting)

## Special Reminder

>> When the transceiver is in transmitter mode, the fan will automatically cool the transceiver regardless of the Temperature Testing settings.

When the transceiver is standby, press the **MENU** + **3** (QT/OT) + **7** (SET-D) keys and the screen will display:



Press the **MENU** key to access the settings menu, and after pressing **▲** / **▼** keys to select the required parameters, press the **MENU** key to confirm, and the **EXIT** key to return to standby.

### Voltage Testing (LOW -V) - Menu 38

When the car-mounted transceiver is installed in a car or another unstable power source (such as a car battery, etc), please activate this function in order to prevent the car-mounted transceiver from consuming electricity over an extended period, rendering the equipment unable to supply electricity for regular work.

The lowest voltage can be set internally by the car-mounted transceiver

When the transceiver is standby, press the **MENU** + **3** (QT/OT) + **8** (TDR) keys and the screen will display:

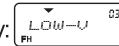

Press the **MENU** key to access the settings menu, and after pressing **▲** / **▼** keys to select the required parameters, press the **MENU** key to confirm,

46

and the **EXIT** key to return to standby.ON (activate) or OFF (deactivate)

## Special Reminder

>> When the voltage is too low, a voice prompt will sound every 10 seconds, and if Voltage Testing is active, the transceiver will automatically power off when the voltage is insufficient. If the voltage is found to be too high, transmission will be blocked.

### Voice scrambler (SCRAM) - Menu 39

This function is a kind of special speech handling, activating voice scrambling avoids the user's speech being overheard by users of transceivers who are not using the scrambling function.

Press the **MENU** + **3** (QT/OT) + **9** (SIL) keys, and the screen will display:



Press the **MENU** key to access the settings menu, and after pressing **▲** / **▼** keys to select A, press the **MENU** key to confirm, and the **EXIT** key to return to standby.

There are selectable 8 voice scrambling groups (1-8), and OFF deactivates.

## Special Reminder

>> The voice scrambler is optional!

### CTCSS scanner saving types(SC-QT) - Menu40

The transceiver is in CTSS scanning, at the time when scanning on the others, there will be 3 saving types to choose from:

- 1.Save the current transceivers as decoder and encoder(All)
- 2.Save the current transceivers as encoder(Encoder)
- 3.Save the current transceivers as decoder(Decoder)

When the transceiver is standby, press the **MENU** + **4** (MEMBER) + **9** (SCRAM) keys and the screen will display:

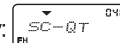

Press **▲** or **▼** to select, press the **MENU** to confirm, and press the **EXIT** key to exit.

## Menu operations

### Noise reduction settings (ANS) - Menu 41

When there is an environmental noise, using this function can effectively reduce the environmental noise interference and clearly receive transmission. There are 3 selections to reduce the noise: the normal noise reduction (NORMAL), the strong noise reduction (STRONG), and OFF.

When the transceiver is standby, press the **MENU** + **4 MEMER** + **1 BAND** keys and the screen will display: 

Press **▲** or **▼** to choose, press **MENU** to confirm and press the **EXIT** key to exit.

### Scan group settings(SC-GROUP) - Menu 42

The scan group settings are the way that a transceiver can create groups through inputting channel data, as well as set channel scanning groups. Channel setting is only set toward the set channel group.

Scan group settings have: ALL channel, as well as 1-4 individual scanning groups.

When the transceiver is standby, press the **MENU** + **4 MEMER** + **3 D-SCAN** keys and the screen will display: 

Press **▲** or **▼** to select, press **MENU** to confirm, and press **MENU** the **EXIT** key to return.

### Frequency Radio function(FM-RADIO) - Menu 43

You can enter the FM radio function by using this function.

When the transceiver is standby, press the **MENU** + **4 MEMER** + **5 OFF/ON** keys and the screen will display: 

Press the **▲** or **▼** keys to select, when select ON, press the **MENU** key to enter FM radio, when select OFF, press **MENU** to return to standby mode.

### Reset Settings (Reset)- Menu 44

Functional Parameter Reset (VFO): resets all functional settings to factory default values, but channel parameters are not reset.

Total Parameter Reset (ALL): resets all of the transceiver's functional settings and channel parameters to factory values.

When the transceiver is standby, press the **MENU** + **4 MEMER** + **4 MEMER** keys and the screen will display: 

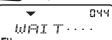
Press the **MENU** key to access the settings menu, and after pressing the up and down keys to select the desired parameter, press **MENU** and the screen will display: 

After the vehicle transceiver resets functional parameters (VFO) (ALL) resets all functional parameters, the transceiver will restart and return to standby mode.

48

## Using FM Receiver mode

### 1.Opening FM Receiver mode

When the transceiver is standby, press the **MENU** + **4 MEMER** + **5 OFF/ON** key, select "on", and press **MENU** to enter FM Radio.

### 2.Frequency selection of FM Receiver mode

When in FM radio mode, press the **2 MRZ** key to enter frequency settings, at this time the screen will display: 

Now, input the desired frequency (4 digits), and if the input frequency is within the scope of the transceiver's range, it will be successfully established.

If the input frequency is beyond the transceiver's range, the setup will fail and the transceiver will revert to the last frequency which was set.

Example 1:Setting FM Waveband 105.9MHz

When the transceiver is standby, press the **2 MRZ** key to access the FM receiver function, (at this point the screen will display the default frequency or the one previously used, and the screen will display "FM" on the top-right of the screen).

Press the **2 MRZ** key to access frequency settings, and the screen will display 8 horizontal lines; press **1 BAND** **0 SCRAM** **5 HIL** **9 SEL** in order, and the screen will display 105.9MHz, and frequency setup is complete.

Example 2:Setting FM Waveband 90.4MHz

When the transceiver is standby, press the **8 YDR** key to access the FM receiving function, press **2 MRZ** to access FM settings, and 8 horizontal lines will be displayed on the screen; press **9 SEL** **0 SCRAM** **4 MEMER** in order, and the screen will display 90.4MHz, and frequency setup will complete.

### 3.storing FM Receiver mode

The transceiver can store 20 FM radio channels.

Saving an FM Reception Channel.

When in FM Waveband mode, press the **MENU** key, and the screen will display: 

After pressing the **▲** / **▼** key, select the channel code you wish to save, press **MENU** to confirm, and the transceiver will automatically return to the FM waveband frequency display interface.

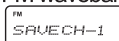
Example: when in FM waveband mode, save the displayed frequency to channel "5" while in FM waveband mode, press the **MENU** key, and the screen will display: 

## Menu operations

Press **▲** / **▼** or the **5** **MR** key, and the LCD screen will display: 

Press the **MENU** key to confirm, and the car platform will automatically return to the FM waveband frequency display interface.

### 4. Exiting FM Receiver mode

When in receiver mode, press **MENU** the key, and the screen will display: 

Press the **EXIT** key to return to FM radio.

50

## Repeater usage

 Wouxun

Twin Band FM Transceiver

### 1. Twin direction repeater channel selection

When the transceiver is standby, press the **MENU** + **2** **MRZ** + **8** **IDR** keys and the screen will display: 

Press the **MENU** key to access the menu, and after pressing the **▲** / **▼** keys to select the required channel, press the **MENU** key to confirm, and the **EXIT** key to return to standby.

### 2. "RPT-SPK" repeater PTT selection

When the transceiver is standby, press the **MENU** + **3** **DSCAN** + **1** **BAND** keys and the screen will display: 

Press the **MENU** key to access the settings menu, and after pressing **▲** / **▼** keys to select NO, press the **MENU** key to confirm, and the **EXIT** key to return to standby.

### 3. "RPT-SPK" Repeater SPK selection

When the transceiver is standby, press the **MENU** + **3** **DSCAN** + **0** **B** keys and the screen will display: 

Press the **MENU** key to access the settings menu, and after pressing **▲** / **▼** keys to select NO, press the **MENU** key to confirm, and the **EXIT** key to return to standby.

### 4. Twin direction cross-band repeater entry

When the transceiver is standby, press the **MENU** + **3** **DSCAN** + **2** **MRZ** keys and the screen will display: 

Press the **MENU** key to access, press **▲** / **▼** to select the directional cross-band repeater (AUTO) press **MENU** to confirm.

At this time the transceiver will restart and enter the twin directional cross-band directional repeat mode.

When the twin directional repeater "RPT-PPT" repeater PTT is ON activated, you only need to press the [PTT] to stop repeater transmission and reception. When this happens you can directly transmit through the directional frequency using the transmitter to transmit, Release the [PTT] key to switch to twin direction repeater standby mode.

When the twin directional repeater "RPT-SPK" repeater SPK is ON activated, if the twin direction repeat receives an effective carrier wave signal, the speakers will emit a tone, and simultaneously send out the received signal out into space on another frequency.

## Handset microphone encoding function

### Dual-tone Encoding (Handset Function)

This device features dual-tone encoding; press the number pad or other keys on the handset when transmitting to activate dual-tone multi-frequency encoding.

The number pad corresponds to Multi-tone Encoding as follows:

MENU	▲	▼	EXIT	→	A	B	C	D
1 BAND	2 MHz	3 07/0T	* SCAN	→	1	2	3	*
4 MEMBER	5 NL	6 00/0B	0 SCRAM	→	4	5	6	0
7 SET-D	8 TDR	9 SQL	# LOCK	→	7	8	9	#

Vehicle-mounted transceiver encoding function usage:

When pressing the [PTT] key under transmission mode\*press the key on the handset microphone and it will transmit dual tone multi-frequency (DTMF) encoding.

### Remote control function

To use the remote control function you must first activate it, at the same time you must set the transceivers I.D number, and master control number. These settings can only be set using the programming software.

- 1.Open the KG-UV920R programming software.
- 2.Connect the transceiver to your PC(Computer)

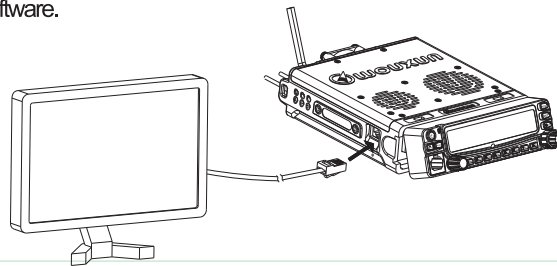

52

## Remote control function

Wouxun

Twin Band FM Transceiver

### 1.Remote control activation

The remote control function can only be set through the programming software.

In the programming software "remote control function" bar choose the remote control activation selection

Master control set up:

ANI-EDIT	<input type="text" value="123456"/>	RC POWER	<input checked="" type="radio"/> RC STOP	<input type="radio"/> RC OPEN
MCC-EDIT	<input type="text" value="654321"/>			
SCC-EDIT	<input type="text" value="000000"/>			
Kill	<input type="text" value="AB"/>	Monitoring	<input type="text" value="DA"/>	RC SW-CODE <input type="text" value="BB"/>
Stun	<input type="text" value="CB"/>	Inspection	<input type="text" value="DB"/>	

Control device settings: the control device's caller ID is 123456, and the controlled transceiver's caller ID is 654321, the control device's caller ID can be any value (of 3-6 digits) (if the device is not being controlled, the 3 or 6-digit caller ID is comprised entirely of 0)

Being controlled settings:

ANI-EDIT	<input type="text" value="123456"/>	RC POWER	<input checked="" type="radio"/> RC STOP	<input type="radio"/> RC OPEN
MCC-EDIT	<input type="text" value="000000"/>			
	<input type="text" value="654321"/>			
Kill	<input type="text" value="AB"/>	Monitoring	<input type="text" value="DA"/>	RC SW-CODE <input type="text" value="BB"/>
Stun	<input type="text" value="CB"/>	Inspection	<input type="text" value="DB"/>	

53

## Remote control function

e.g.: the local caller ID is set to 123456, and the being controlled caller ID is 654321, the being control device's caller ID can be any value (of 3-6 digits) (if the device is not being controlled, the 3 or 6-digit caller ID is comprised entirely of 0)

### (1) Long range stun

1. After inputting the above settings, press PTT + the digit 2 key(remote stun) the control device will then send out its own Caller ID+ the fixed code for stun + CB (stun)+local caller ID number(123456). The being control device will send out its own Caller ID (654321) + fixed code CB(stun)+local caller ID number (123456), carrying out being control own caller ID(654321) + Fixed CB (stun) +local caller ID (123456) identification and if the caller ID sent by the control device is the same as the receiving device's set control caller ID, and the receiving device's caller ID is the same as the transmitted controlled devices caller ID, the appropriate stun function. The being control will not work in repeater mode.

### (2) Long range kill

After the controlled device receives the control device's transmission of its own caller ID of 123456+ the fixed code for stun (CB)/ kill (AB)/ monitor (DA)/ inspection (DB) + the controlled device's caller ID of 654321, it will identify each part, and if the caller ID sent by the control device is the same as the receiving device's set control caller ID, and the receiving device's caller ID is the same as the transmitted controlled device's caller ID, the appropriate kill function. Note: the being control will not work in repeater mode.

### (3) Remote monitoring

After the controlled device receives the control device's transmission of its own caller ID of 123456+ the fixed code for monitoring (CB)/ kill (AB)/ monitor (DA)/ inspection (DB) + the controlled device's caller ID of 654321, it will identify each part, and if the caller ID sent by the control device is the same as the receiving device's set control caller ID, and the receiving device's caller ID is the same as the transmitted controlled devices caller ID, the appropriate monitor function. (monitoring time is 15 seconds)

Note: The being control will not work in repeater mode.

### (4) Remote inspection

After the controlled device receives the control device's transmission of its own caller ID of 123456+ the fixed code for inspection (CB)/ kill (AB)/ monitor (DA)/ inspection (DB) + the controlled device's caller ID of 654321, it will identify each part, and if the caller ID sent by the control device is the same as the receiving device's set control caller ID, and the receiving device's caller ID is the same as the transmitted controlled devices caller ID, the appropriate inspection function.

54

Note: the being control will not work in repeater mode.

### II 、 Long distance remote control switch settings:

ANI-EDIT	<input type="text" value="123456"/>	RC POWER	<input type="radio"/> RC STOP <input checked="" type="radio"/> RC OPEN	
MCC-EDIT	<input type="text" value="000000"/>			
SCC-EDIT	<input type="text" value="654321"/>			
Kill	<input type="text" value="AB"/>	Monitoring	<input type="text" value="DA"/>	RC SW-CODE <input type="text" value="BB"/>
Stun	<input type="text" value="CB"/>	Inspection	<input type="text" value="DB"/>	

### Being controlled settings:

Being control device caller ID is set as 654321, for remote control activation choose "Remote control activation"

#### (1) Turning off long distance remote control

The main control can be turned off by manually sending 654321 (being control caller I.D), +Fixed I.D BB (Control activation I.D).

Note: ① After turning off the long distance remote control, the communication indicator is still flashing.

#### (2) Remote control activation

The main control can be turned on by manually sending 654321 (being control caller I.D), +Fixed I.D BB (Control activation I.D)

Note: ① After turning off the long distance remote control, if you want to manually turn on the control, you can turn it on through pressing the front panel POWE key.

## Remote control function

III. Long range transceiver repeat channel control settings:

ANI-EDIT	<input type="text" value="123456"/>	RC POWER			
MCC-EDIT	<input type="text" value="000000"/>	<input checked="" type="radio"/> RC STOP	<input type="radio"/> RC OPEN		
SCC-EDIT	<input type="text" value="654321"/>				
Kill	<input type="text" value="AB"/>	Monitoring	<input type="text" value="DA"/>	RC SW-CODE	<input type="text" value="BB"/>
Stun	<input type="text" value="CB"/>	Inspection	<input type="text" value="DB"/>		

**Being controlled settings:**

Being control caller ID is set as 654321

56

## Optional Accessories

**Wouxun**

Twin Band FM Transceiver

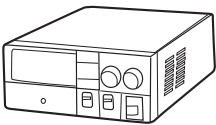

Switching Power Supply (20A)

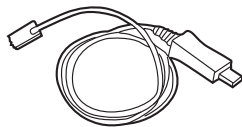

USB Programming Cable



Mobile Speaker / Mic



Mobile Antenna

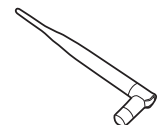

Directional Antenna



Omni-antenna



Clamps Install Mount

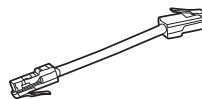

Connection Cable

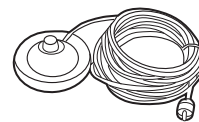

Strong Magnetic Mount

57

## Troubleshooting

Before assuming your transceiver is broken, please check your transceiver according to the following table; if the problem persists, you can reset the transceiver, which sometimes resolves problems with settings.



Fault	Solution
Reception prompt remains but speaker is silent	<ul style="list-style-type: none"> <li>» Check that the volume knob has been set to maximum.</li> <li>» Please reset sub-audio settings to check whether different channels from other group members have been set.</li> <li>» Check whether squelch settings are correct.</li> </ul>
Keypad is unresponsive	<ul style="list-style-type: none"> <li>» Check whether keypad has been locked.</li> <li>» Check whether other keys have been pressed.</li> </ul>
Other voices (not from group members) appear in the channel.	<ul style="list-style-type: none"> <li>» Please change the QT frequency.</li> </ul>
Receive regular voice pause (About 3 second intervals)	<ul style="list-style-type: none"> <li>» Please see if the "PRICH-SW"(Priority scanning switch) is turned on.</li> </ul>
Can not enter scanning mode	<ul style="list-style-type: none"> <li>» Please see if the scan group channel, Scan Add function is turned on.</li> </ul>
Transceiver automated activation/deactivation switch	<ul style="list-style-type: none"> <li>» Please make sure all used power sources are under 11.5V, or if the "APO" switch is on.</li> </ul>
When pressing the transceiver PTT key to transmit, there is no output power and no reception	<ul style="list-style-type: none"> <li>» See if it has been stunned or killed.</li> </ul>
Cannot set up the cross-band repeater	<ul style="list-style-type: none"> <li>» Please make sure A/B area's is on the cross-band repeaters operating frequency.</li> </ul>
Cannot transmit in repeat mode	<ul style="list-style-type: none"> <li>» Please check to see if the receivers squelch and CTCSS settings are correct.</li> </ul>

58

## Announcement

 **Wouxun**

Twin Band FM Transceiver

 Wouxun endeavors to achieve the accuracy and completeness of this manual, but it is still not perfect for any possible omissions or printing errors.  All the above is subject to be updated without prior notice.

Edition:KG-UV920R-1206-V1

59